

CH 650

Self-Erecting Hydraulic Piling Rig



High Tech Line



COMACCHIO

DRILLING HI-TECH

CH 650

MULTIPURPOSE PILING RIG

The CH 650 is a multipurpose drilling rig mounted on a dedicated excavator carrier with an operating weight of 70 tons (154,300 lbs). The rig is self-erecting and can be transported with minor disassembly of the machine, thus allowing for easy and fast rig-up.

The CH 650 can be offered both in CPD (Cylinder Pulldown) and WPD (Winch Pulldown) configuration. The innovative rotary head design adopted by Comacchio allows for the use of Kelly bars of various diameters, including HD (Heavy Duty) bars and XHD (Extra Heavy Duty) bars, up to a maximum length of 15 m (49' 2"), with minor changes on the rotary head.

The design of the CH 650 adapts to a wide range of drilling technologies including:

CBP (Cased Bored Piles) cased bored piles with casing driven directly by rotary head or optionally by casing oscillator powered by the base carrier;

BP (Bored Piles) deep uncased bored piles stabilized by drilling fluid or dry hole;

CFA (Continuous Flight Auger) piles by means of long auger string;

DP (Displacement Piles)

SM (Soil Mixing)

LDTH (Large DTH)

The CH 650 can be offered in different LHR (Low Head Room) configurations, designed for the construction of bored piles in challenging access sites.



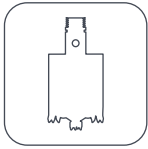

	m.s.	i.s.	BP (Bored Piles)		CBP (Cased Bored Piles)	
Max. pile diameter CPD	mm	ft-in	2.200 ⁽¹⁾ - 2.500 ⁽¹⁾	7' 2" ⁽¹⁾ - 8' 2" ⁽¹⁾	1.900 ⁽⁵⁾	6' 3" ⁽⁵⁾
Max. pile diameter WPD	mm	ft-in	2.000 - 2.500 ⁽¹⁾	6' 7" - 8' 2" ⁽¹⁾	1.700 ⁽⁵⁾	5' 7" ⁽⁵⁾
Max. pile depth CPD	m	ft-in	68 ⁽²⁾⁽⁴⁾	223' 1" ⁽²⁾⁽⁴⁾	68 ⁽²⁾⁽³⁾⁽⁴⁾	223' 1" ⁽²⁾⁽³⁾⁽⁴⁾
Max. pile depth WPD	m	ft-in	69 ⁽²⁾	226' 4" ⁽²⁾	69 ⁽²⁾⁽³⁾	226' 4" ⁽²⁾⁽³⁾
Pile diam with casing oscillator max.	mm	ft-in	-		1.500	4' 11"

(1) tool below mast

(2) using self mounting kelly bar

(3) drill depth; cased depth depending on soil conditions

(4) with mast foot installed

(5) with casing locking keys

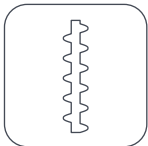

	m.s.	i.s.	CFA (Continuous Flight Auger)	
Max. pile diameter	mm	ft-in	1.000	3' 3"
Max. pile depth (CFA/WPD)	m	ft-in	15,5 + 7 = 22,5	50' 10" + 22' 11" = 73' 9"
Max. pile depth (CFA T4)	m	ft-in	19 + 6 = 25	62' 4" + 19' 8" = 82"

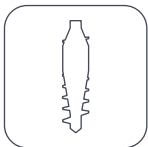

	m.s.	i.s.	DP (Displacement Piles)	
Max. pile diameter	mm	ft-in	600	1' 11"
Max. pile depth	m	ft-in	14,5 + 7 = 21,5	47' 7" + 22' 11" = 70' 6"



	m.s.	i.s.	SM (Soil Mixing)	
Pile diameter	mm	ft-in	400 - 2000 ⁽⁶⁾	1' 4" - 6' 7" ⁽⁶⁾
Max. pile depth	m	ft-in	14,5 + 7 = 21,5	47' 7" + 22' 11" = 70' 6"

(6) according to the soil conditions; tool below mast



	m.s.	i.s.	MP (Micropiles)	
Max. pile diameter	mm	ft-in	620 ⁽⁷⁾	2' ⁽⁷⁾
Stroke of rotary head	mm	ft-in	16.000	52' 6"

(7) according to the clamp size

CH 650

Technical Data

Undercarriage		m.s.	i.s.	High Tech Line			
Type			-		Variable gauge		
Removable tracks			-		No		Optional
Track shoe width	mm	ft-in	800	2' 8"	700	2' 3"	
Track shoe type			-		Triple grouser		
Overall width (retracted side frames)	mm	ft-in	3.000	9' 10"	2.980	9' 9"	
Overall width (extended side frames)	mm	ft-in	4.300	14' 1"	4.280	14'	
Overall length	mm	ft-in	5.860	19' 3"	5.960	19' 7"	
Centre idler to centre sprocket	mm	ft-in	5.000	16' 5"	5.035	16' 6"	
Upperframe							
Width	mm	ft-in			3.000	9' 10"	
Operators' cabin			-		TOPS & FOPS-1 certified, 1.040 mm (3' 5") wide		
Control system type			-		CAN-BUS		
User interface			-		12" Touch Screen		
Tail swing radius	mm	ft-in	3.535	11' 7"	3.480	11' 5"	
Diesel Engine				High Tech Line			
Make and model			-		CAT C9		CAT C9.3
Emission certification			-		EU stage IIIA / US EPA Tier 3		EU stage V / US EPA Tier 4f
Aspiration			-		Turbocharged and charge air cooled		
Power rating (2.000 rpm)	kW	HP	261	350	234	314	
	rpm		1.800		1.550		
Displacement	cc	in ³	8.800	538	9.300	568	
Fuel consumption rate (100% power, rated speed)	g/kWh	lb/hp-hr	222	0.365	202	0.332	
Hydraulic System							
Main pumps flow	l/min	gal/min			2 x 280	2 x 74	
Service pump flow	l/min	gal/min			90	24	
Main Winch							
Type			-		Controlled descent		
1 st layer line pull	kN	lbs			250	56,200	
1 st layer rope speed	m/min	ft/min			76	249	
Rope diameter	mm	in			28	1" 1/8	
Rope layers			-		2		
Useful rope length with 1 / 2 / .. full layers	m	ft-in			34 - 77	111' 6" - 252' 7"	
FEM classification			-		M5 - L2 - T5		
Service Winch							
Type			-		Controlled descent		
1 st layer line pull	kN	lbs			133	29,900	
1 st layer rope speed	m/min	ft/min			64	210	
Rope diameter	mm	in			20	13/16"	
Rope layers			-		3		
FEM classification			-		M5 - L2 - T5		

CH 650

Rotary Head

Torque Diagram

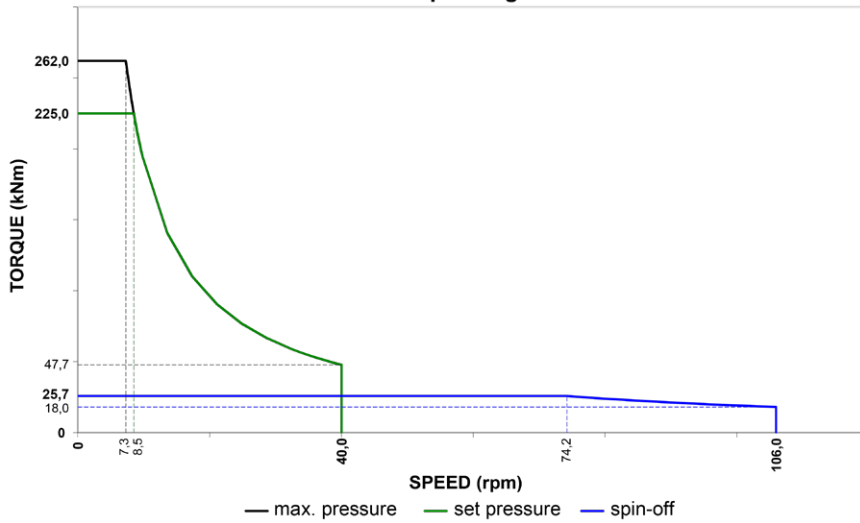

Mix

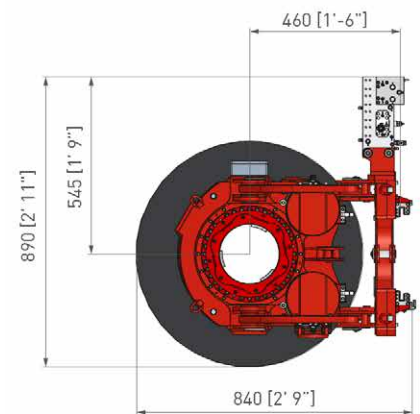
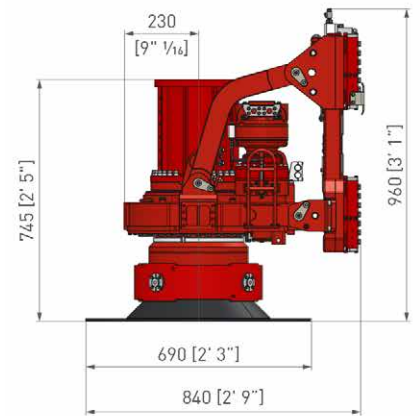
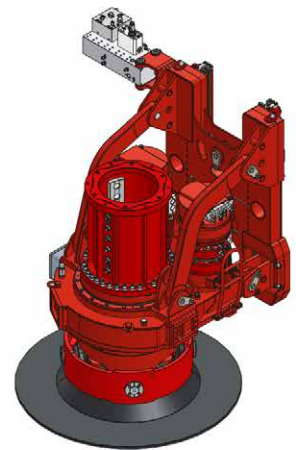
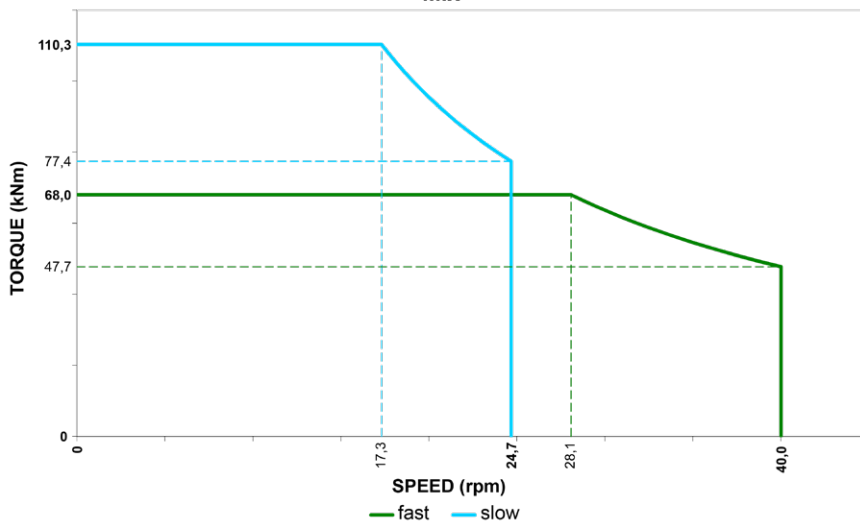

Rotary Head	m.s.	i.s.	CR 26	
Nominal max. torque	kNm	lbf-ft	262 at 35 MPa	193,200 at 5080 psi
Max. torque	kNm	lbf-ft	225 at 30 MPa	166,000 at 4350 psi
Max. drilling speed	rpm		40	
Hydraulic power	kW	HP	200	268
Spin-off speed	rpm		106	
Replaceable drive sleeve	-		Yes	
Replaceable drive keys	-		Yes	

CH 650

Options and Accessories

Standard equipment

Main winch with special grooving	Engine diagnostic panel
Hoist and lowering limit switches on main and service ropes	Transport securing lugs on crawler unit
Swivel for main rope	Work lights
Service rope parking point	Electric refuelling pump and hydraulic oil refilling
Mast inclination measurement on X & Y axes (digital and analog display)	Diagnostic panel for hydraulic, electrical and electronic functions
Automatic vertical mast alignment	Front and top cabin protective grate (top cabin is FOPS-1 certified)
Depth measuring device on main winch	Radio CD player
Rpm measuring device on rotary	Phone charger
Crowd pressure setting	CCS Comacchio Controlling System
Oscillator attachment brackets	Spinoff and Shaker tool dump systems
Heating & air conditioning system	Rotary auto speed management & interactive multiple gear
Emergency mode of operation for engine	Tool box

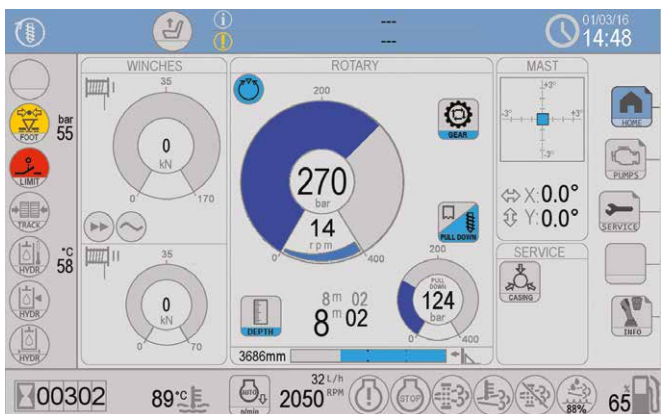

CCS: Home page

Optional equipment

Removable tracks undercarriage	Flange for casing driving
Biodegradable oil	Welding equipment & generator
Freefall auxiliary winch	Air compressor kit
Main and aux winch load cells	Washing kit
Swivel for auxiliary rope	Videocamera set
Central lubrication system	Prearrangement for casing oscillator
Automatic lubrication kit for rotary sliding guides	Casing oscillator
CFA cleaner (star or hydraulic type)	Vibratory equipment for steel cage
Flange for bucket opening	Data logger
Cardan joint	ComNect system

CE conformity kit

Machine travel remote radio control	Video cameras set
Main and aux winch load cells	CFA cleaner
Side walkways w/handrails	Rubber strip on auger guide



CH 650

Kelly bars

Comacchio Innovative Kelly bar system

Three bar sizes are available with minor changes on the rotary head.

Kelly bar sizes	m.s. i.s.		Outer diameter	
	mm	ft-in	mm	ft-in
L (standard)	394	1' 3" 1/2		
HD (Heavy Duty)	406	1' 4"		
XHD (Extra Heavy Duty)	419	1' 4" 1/2		



X (approx.)	mm	ft-in	1.500	4' 11"
U (approx.)	mm	ft-in	1.500	4' 11"
$Z = H - X - U$				

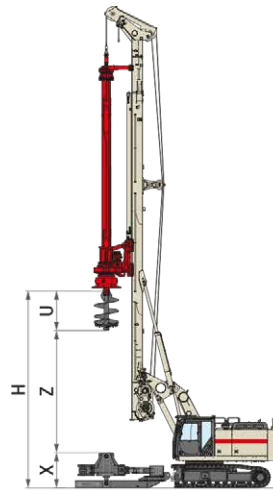

Depth	Kelly Bars				WPD				CPD				
	N.	Length		Weight ⁽²⁾		Depth ⁽³⁾		H ⁽⁴⁾		Depth ⁽⁵⁾		H ⁽⁴⁾	
		(m)	(ft-in)	(kg)	(lbs)	(m)	(ft-in)	(m)	(ft-in)	(m)	(ft-in)	(m)	(ft-in)
Locking or friction	4	8	26' 2"	5.710	12,690	28,40	93' 2"	10,60	34' 9"	27,10	88' 10"	8,96	29' 4"
	4	9	29' 6"	6.320	14,040	32,40	106' 3"	9,60	31' 5"	31,10	102' 0"	8,96	29' 4"
	4	10,5	34' 5"	7.170	15,930	38,40	125' 11"	8,10	26' 6"	37,10	121' 8"	8,10	26' 6"
	4	12	39' 4"	7.750	17,220	44,40	145' 8"	6,60	21' 7"	43,10	141' 4"	6,60	21' 7"
	4	13	42' 7"	8.240	18,310	48,40	158' 9"	5,60	18' 4"	47,10	154' 6"	5,60	18' 4"
	4	13,5	44' 3"	8.480	18,840	50,40	165' 4"	5,10	16' 8"	49,10	161' 1"	5,10	16' 8"
	4	14	45' 11"	8.730	19,400	52,40	171' 10"	4,60	15' 1"	51,10	167' 7"	4,60	15' 1"
	4	14.5 ⁽¹⁾	47' 6" ⁽¹⁾	8.970	19,930	54,40	178' 5"	4,10	13' 5"	53,10	174' 2"	4,10	13' 5"
	4	15 ⁽¹⁾	49' 2" ⁽¹⁾	9.220	20,490	56,40	185' 0"	3,60	11' 9"	55,10	180' 9"	3,60	11' 9"
	Friction	5	8	26' 2"	5.810	12,910	35,20	115' 5"	10,60	34' 9"	34,00	111' 6"	8,96
5		9	29' 6"	6.290	13,980	40,20	131' 10"	9,60	31' 5"	39,00	127' 11"	8,96	29' 4"
5		10,5	34' 5"	7.020	15,600	47,70	156' 5"	8,10	26' 6"	46,50	152' 6"	8,10	26' 6"
5		12	39' 4"	7.750	17,220	55,20	181' 1"	6,60	21' 7"	54,00	177' 1"	6,60	21' 7"
5		13	42' 7"	8.240	18,310	60,20	197' 6"	5,60	18' 4"	59,00	193' 6"	5,60	18' 4"
5		13,5	44' 3"	8.480	18,840	62,20	204' 0"	5,10	16' 8"	61,00	200' 1"	5,10	16' 8"
5		14	45' 11"	8.730	19,400	64,20	210' 7"	4,60	15' 1"	63,00	206' 8"	4,60	15' 1"
5		14.5 ⁽¹⁾	47' 6" ⁽¹⁾	8.970	19,930	66,70	218' 9"	4,10	13' 5"	65,50	214' 10"	4,10	13' 5"
5		15 ⁽¹⁾	49' 2" ⁽¹⁾	9.220	20,490	69,20	227' 0"	3,60	11' 9"	68,00	223' 1"	3,60	11' 9"

(1) Self-mounting only if mast foot is installed (2) Kelly Diameter 406 mm (1' 4")
 (3) Depth to be reduced by 1,3 m (4' 3") in case mast foot is not installed (4) Max. Height of bottom kelly pin above ground
 (5) Depth to be increased by 1,6 m (5' 3") in case mast foot is installed

CH 650

Casing Oscillator Arrangement

WPD

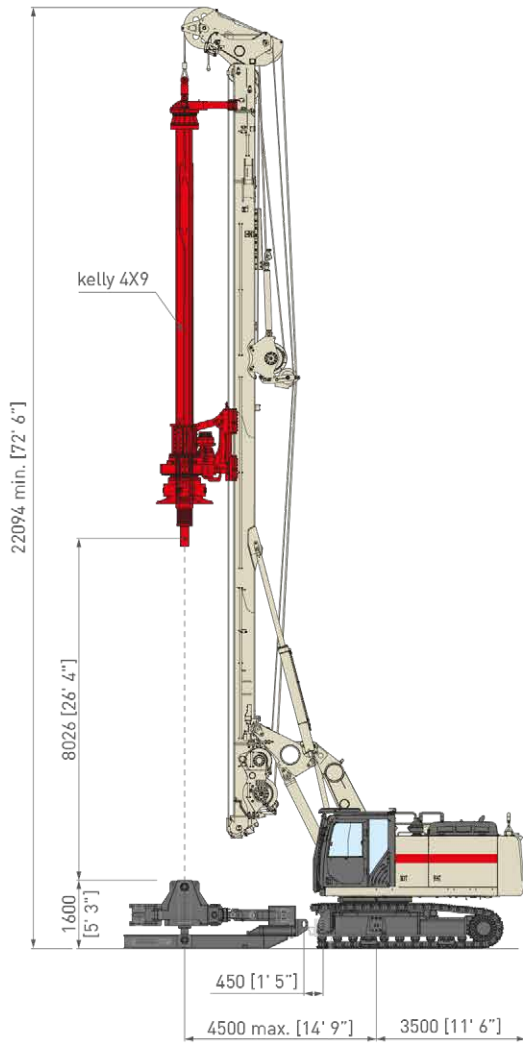

CPD

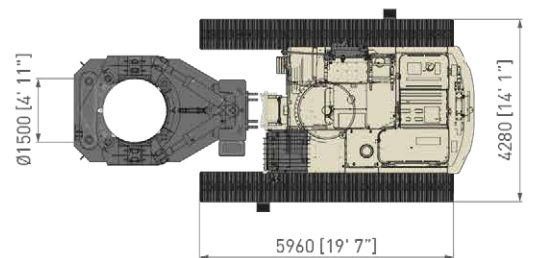
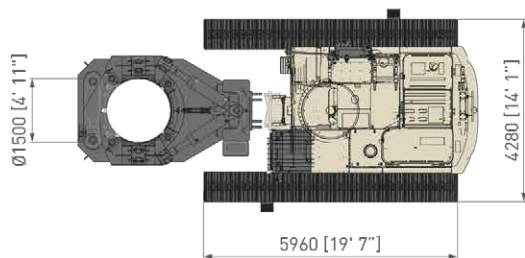
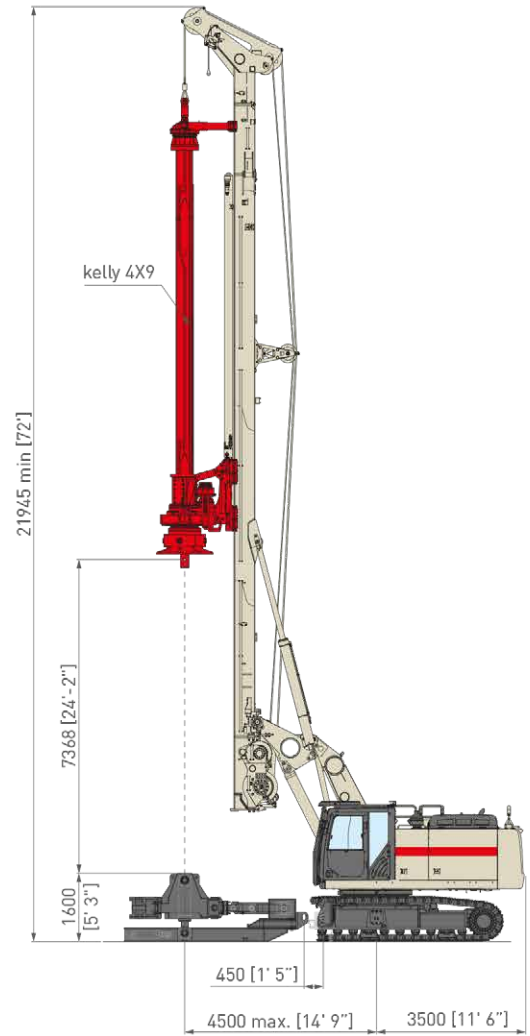

CH 650 - WPD

Overall dimensions

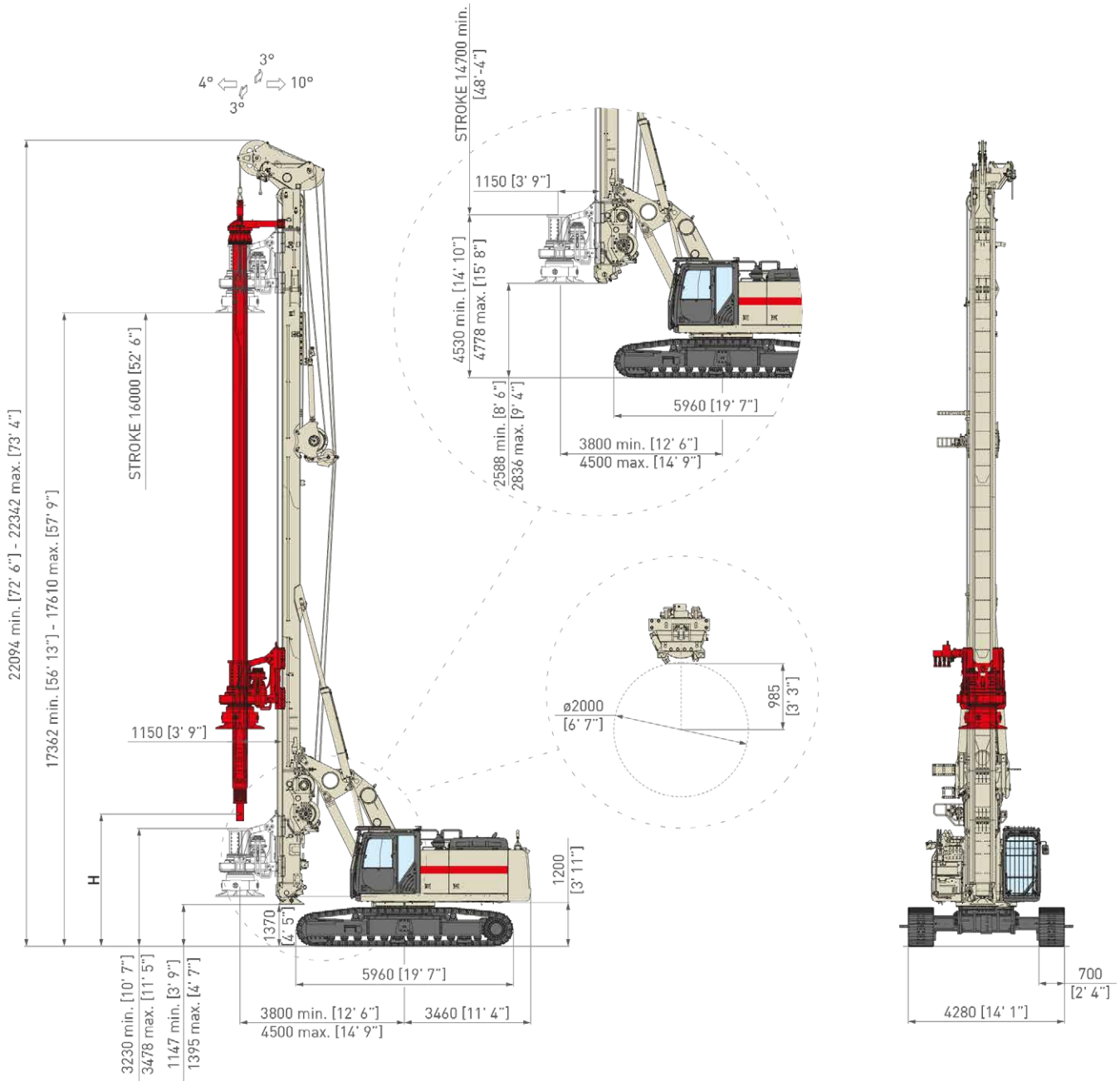

WPD (Winch Pull Down)

	m.s.	i.s.		
Stroke c/w mast foot	mm	ft-in	16.000	52' 6"
Stroke c/w lower reeving box	mm	ft-in	14.700	48' 3"
Max. pull up force	kN	lbs	330	74,200
Max. pull down force	kN	lbs	330	74,200
Speed down	m/min	ft/min	44	144
Max. pile diameter	mm	ft-in	2.000 - 2.500 ⁽¹⁾	6' 7" - 8' 2" ⁽¹⁾
Operating weight w/o tool	kg	lbs	71.600 ⁽²⁾	159,100 ⁽²⁾

Notes

(1) with - without bottom mast element

(2) c/w kelly bar 4 x 10,5 m [4 x 34' 5"] Ø 406 [1' 4"] and bucket opening flange



CH 650 - CPD

Overall dimensions

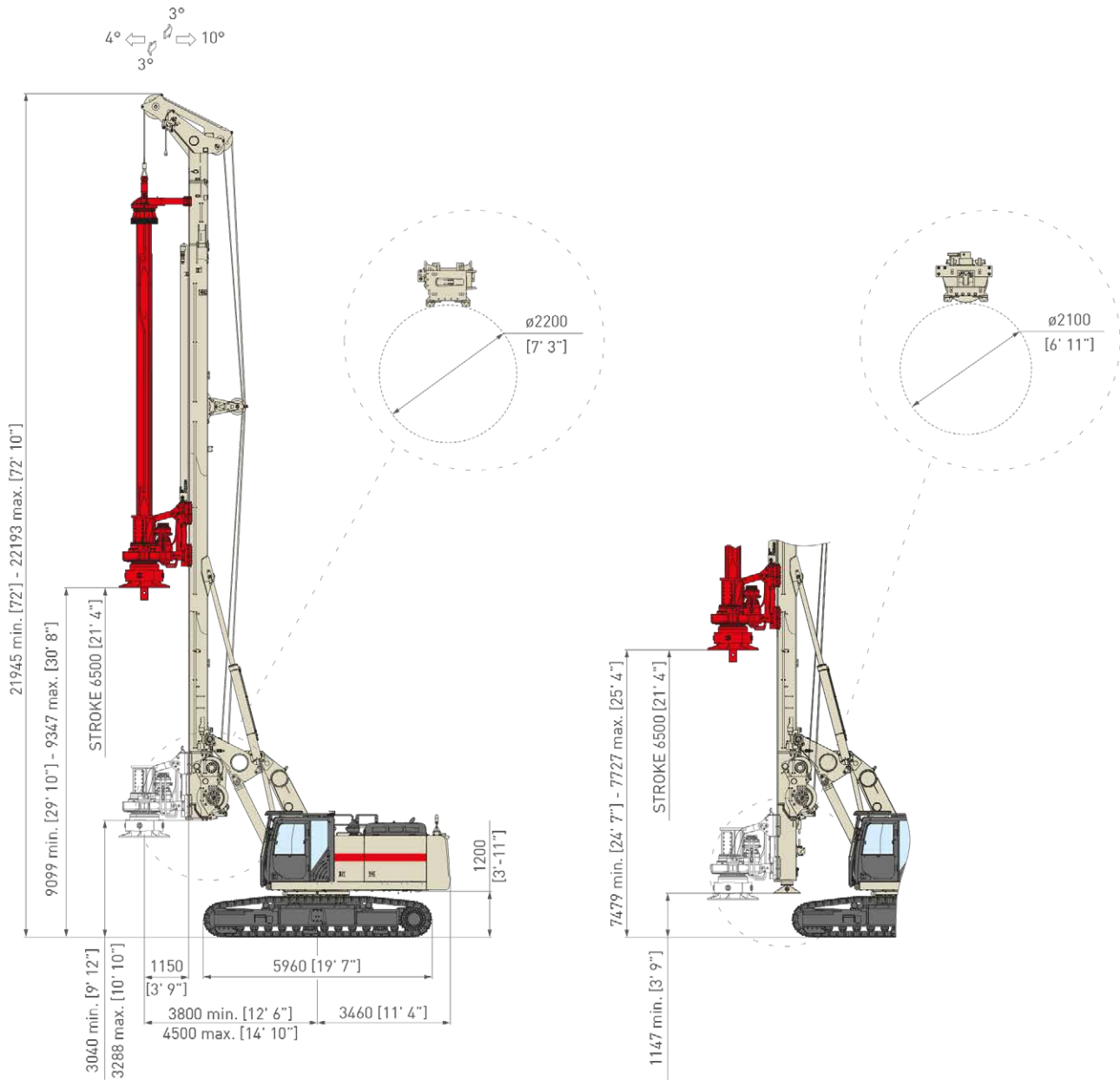

CPD (Cylinder Pull Down)

	m.s.	i.s.		
Stroke	mm	ft-in	6.500	21' 4"
Max. pull up force	kN	lbs	280	63,000
Max. pull down force	kN	lbs	232	52,200
Speed down	m/min	ft/min	25	82
Max. pile diameter	mm	ft-in	2.200 ^{(1) (3)} - 2.500 ⁽²⁾	7' 1/2 ^{(1) (3)} - 8' 2" ⁽²⁾
Operating weight w/o tool	kg	lbs	69.900 ⁽⁴⁾	155,300 ⁽⁴⁾

Notes

(1) tool in front of mast

(2) tool below mast

(3) 2.100 mm [6' 10"] with mast pad

(4) c/w kelly bar 4 x 10,5 m [4 x 34' 5"] Ø 406 [1' 4"] and bucket opening flange; w/o bottom mast element

CH 650 - LHR

Overall dimensions

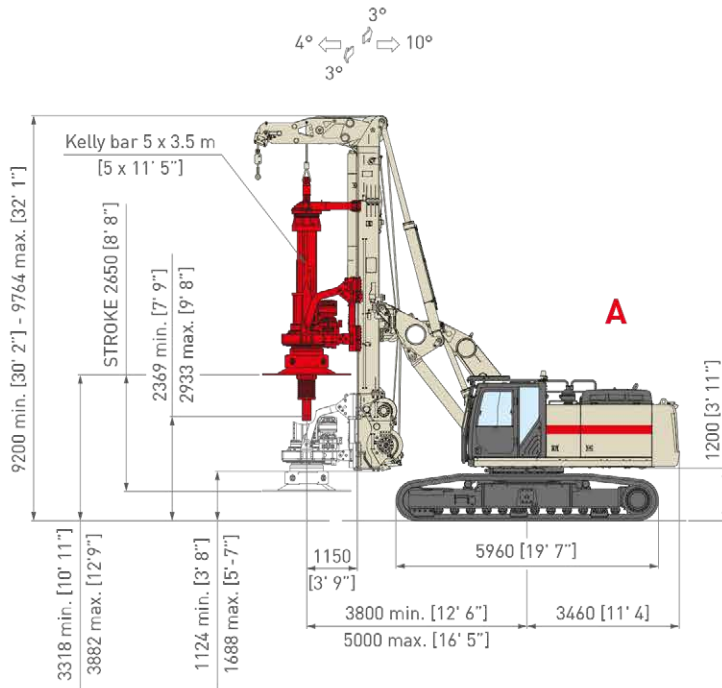

MODULAR

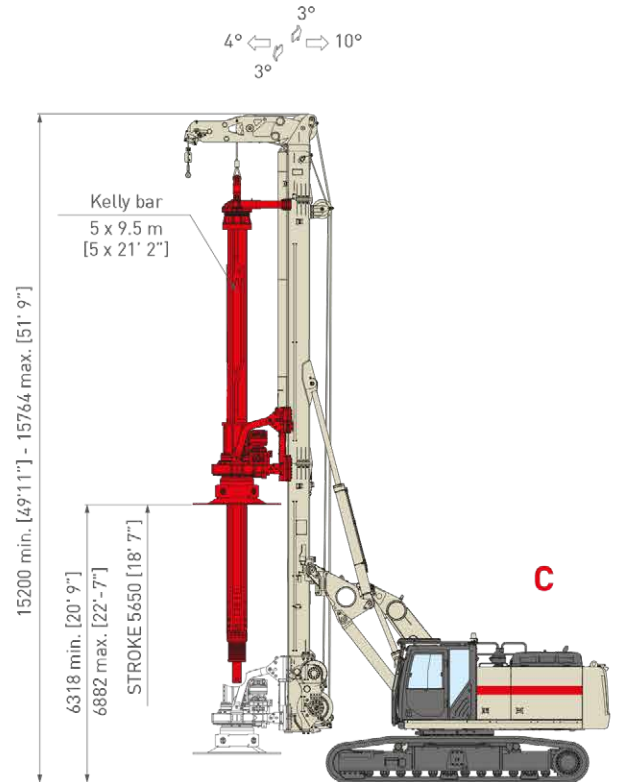
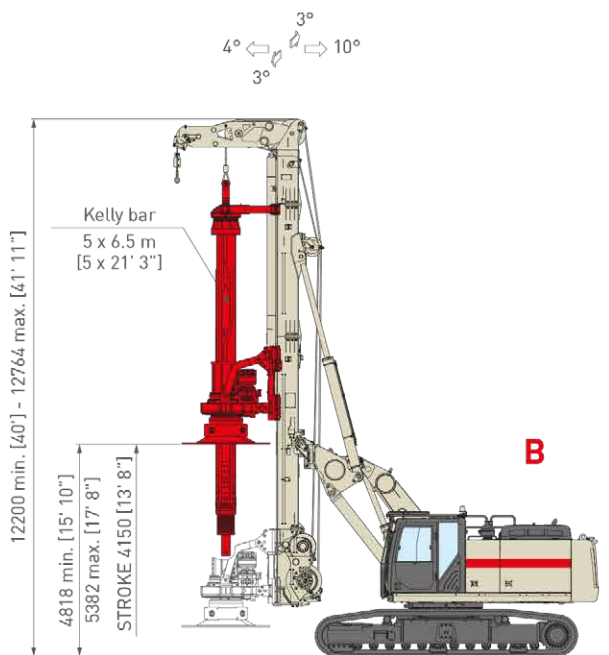

LHR (Low Head Room)	m.s.	i.s.	A		B		C	
Height	m	ft	9,2	30'	12,2	40'	15,2	50'
Stroke of pull down cylinder	mm	ft-in	2.650	8' 8"	4.150	13' 8"	5.650	18' 7"
Max. pile diameter	mm	ft-in			2.200 ⁽¹⁾	7' ½ ⁽¹⁾		
Max. pile depth	m	ft-in	13 ⁽²⁾⁽³⁾	42' 8" ⁽²⁾⁽³⁾	28 ⁽²⁾⁽⁴⁾	91' 10" ⁽²⁾⁽⁴⁾	43 ⁽²⁾⁽⁵⁾	141' 1" ⁽²⁾⁽⁵⁾
Operating weight w/o tool	kg	lbs	62.650 ⁽³⁾	139,250 ⁽³⁾	66.850 ⁽⁴⁾	148,550 ⁽⁴⁾	69.750 ⁽⁵⁾	155,000 ⁽⁵⁾

Notes

- (1) 2.100 mm (6' 10") with mast foot
- (2) tool height 1.500 mm (4' 11")
- (3) c/w kelly bar 5 x 3,5 m (5 x 11' 5") Ø 419 (1' 4" ½) and bucket opening flange
- (4) c/w kelly bar 5 x 6,5 m (5 x 21' 4") Ø 419 (1' 4" ½) and bucket opening flange
- (5) c/w kelly bar 5 x 9,5 m (5 x 31' 2") Ø 419 (1' 4" ½) and bucket opening flange

CH 650 - CFA

Overall dimensions

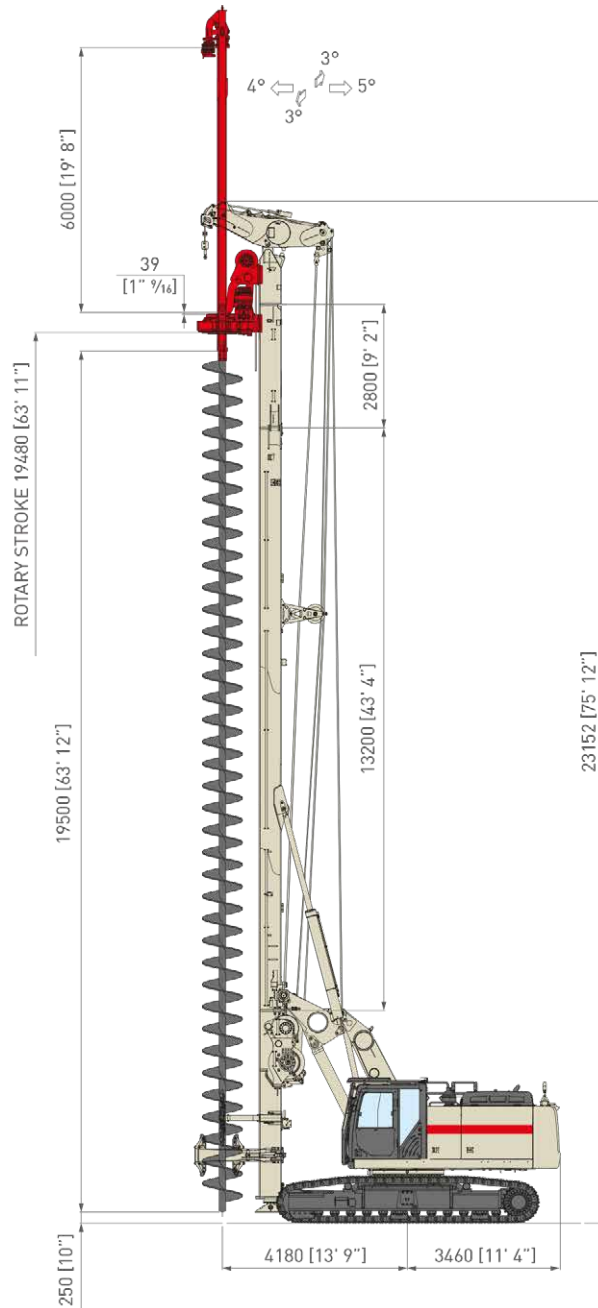

CFA	m.s.	i.s.		
Max. pile diameter	mm	ft-in	1.000	3' 3"
Max. length of augers	m	ft-in	19,5	63' 11"
Max. length of auger extension	m	ft-in	6	19' 8"
Max. pile depth	m	ft-in	19 + 6 = 25	62' 4" + 19' 8" = 82'
Extraction force	kN	lbs	650	146,130
Crowd force on auger (optional)	kN	lbs	100	22,500
Operating weight w/o drill string	kg	lbs	64.500	143,300

CH 650 - CFA/WPD

Overall dimensions

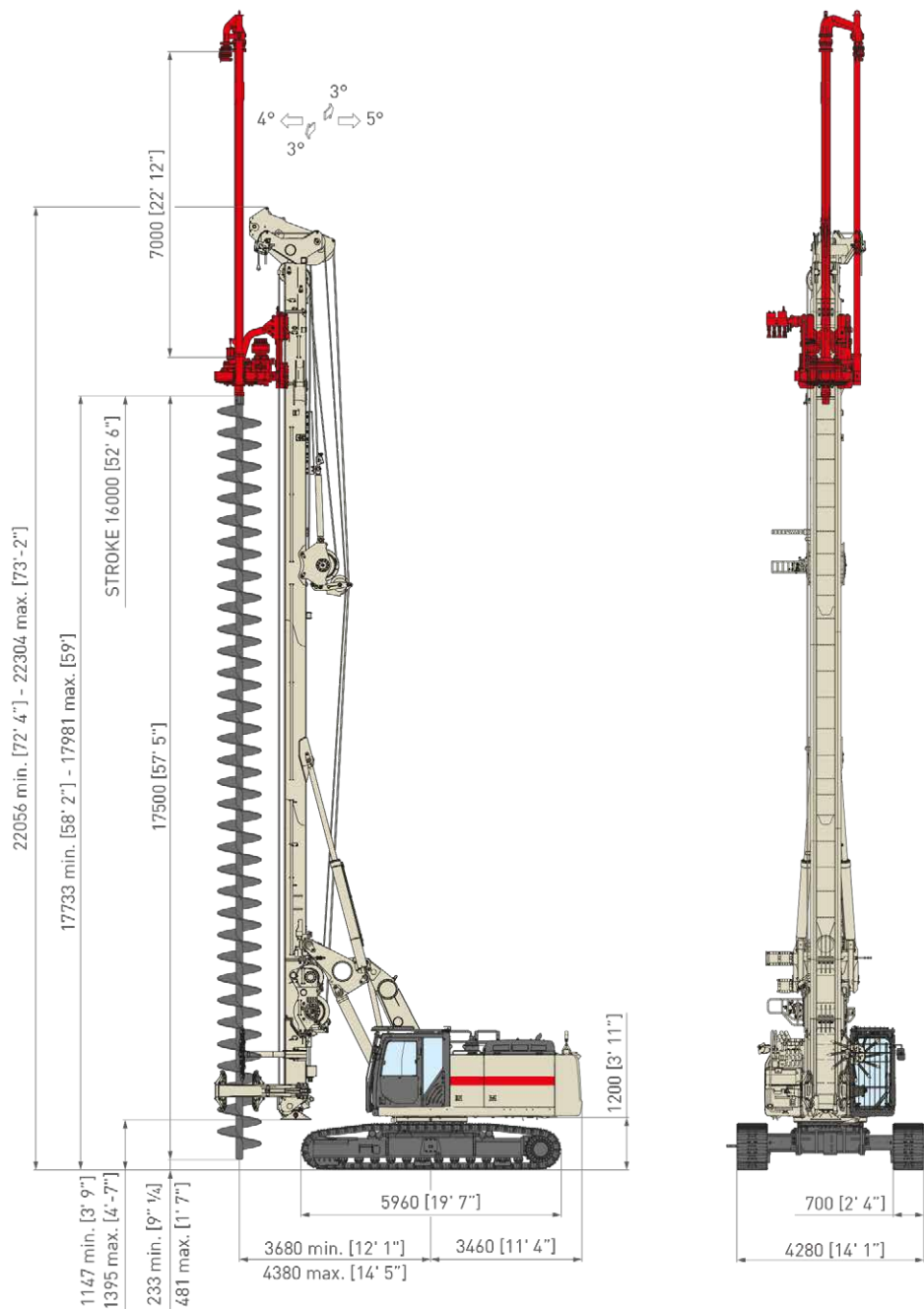

CFA/WPD (Quick Conversion CFA)

	m.s.	i.s.		
Max. pile diameter	mm	ft-in	1.000	3' 3"
Max. length of augers	m	ft-in	17,5	57' 5"
Max. length of auger extension	m	ft-in	7	22' 11"
Max. pile depth	m	ft-in	15,5 + 7 = 22,5	50' 10" + 22' 11" = 73' 9"
Extraction force	kN	lbs	580	130,400
Crowd force on auger	kN	lbs	140	31,500
Operating weight w/o drill string	kg	lbs	65.650 ⁽¹⁾	145,900 ⁽¹⁾
Max drill string weight	kg	lbs	12.000 ⁽¹⁾	26,650 ⁽¹⁾

Note

(1) with auger extension, auger cleaner, swivel and swan neck

CH 650 - DP/SM

Overall dimensions

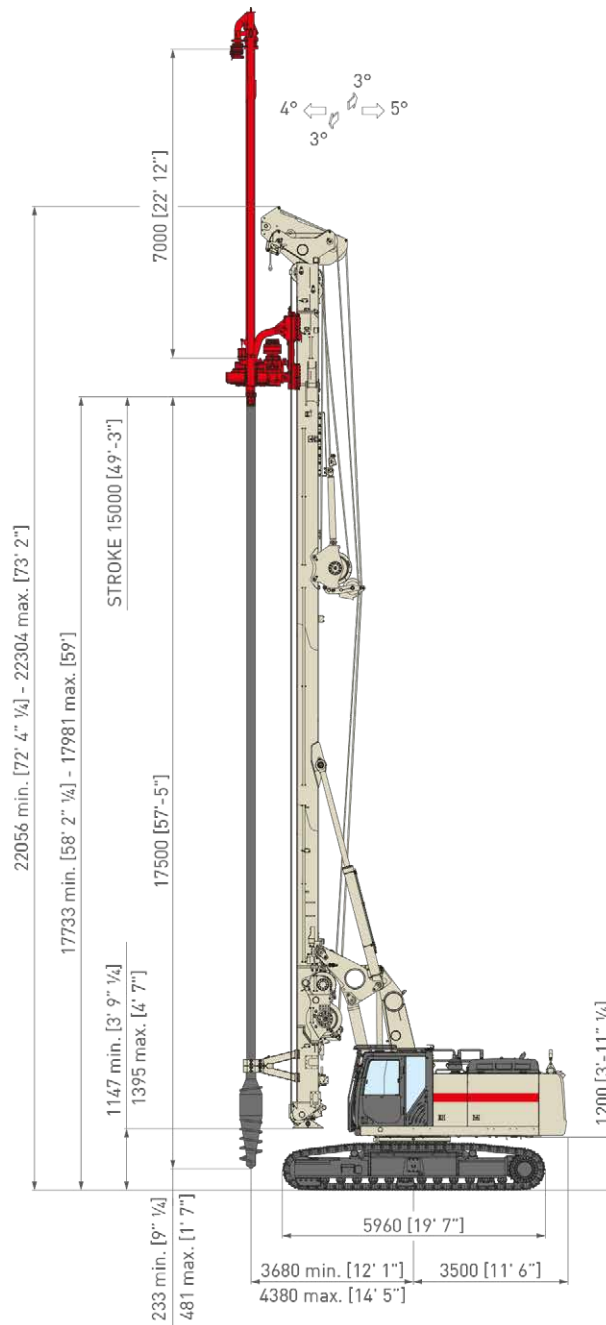

WPD (Winch Pull Down) / DP-SM	m.s.	i.s.	DP (Displacement Piles)		SM (Soil Mixing)	
			mm	in	mm	in
Max. pile diameter			600	1' 11"	400 - 2000 ⁽¹⁾	1' 4" - 6' 7" ⁽¹⁾
Max. drill string length	m	ft-in	17,5	57' 5"		
Max. length of drill string extension	m	ft-in	7	22' 11"		
Max. pile depth	m	ft-in	14,5 + 7 = 21,5	47' 7" + 22' 11" = 70' 6"		
Extraction force	kN	lbs	580	130,400		
Max. pull down force	kN	lbs	140	31,500		
Operating weight w/o tool, sleeve and piping	kg	lbs	60.000	133,400		

Note

(1) according to the soil conditions; tool below mast



CH 650

Transport dimensions

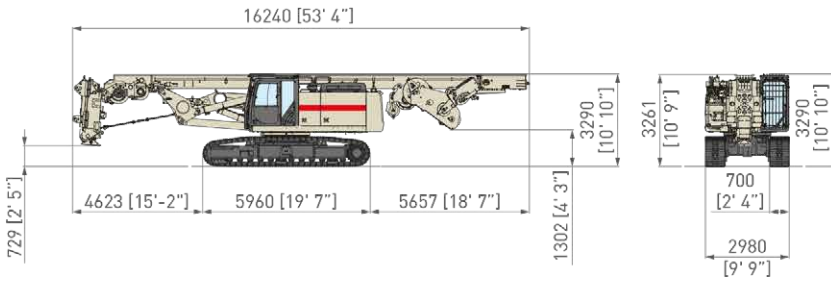

	m.s.	i.s.	WPD	
Transport weight	kg	lbs	61.000	135,500

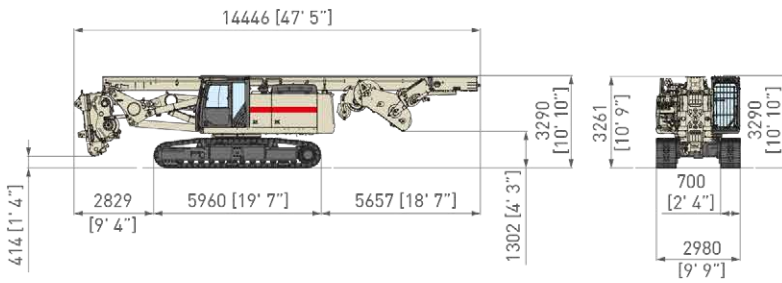

	m.s.	i.s.	WPD w/o mast foot	
Transport weight	kg	lbs	60.200	133,800

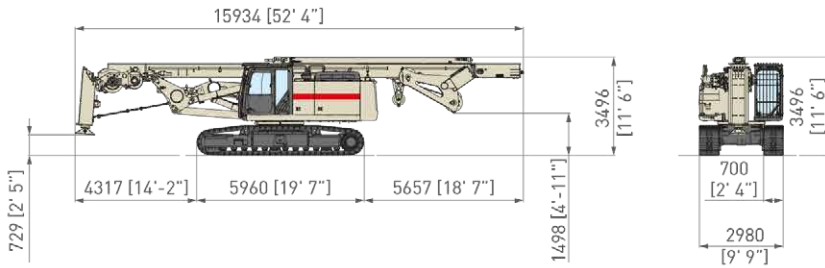

	m.s.	i.s.	CPD	
Transport weight	kg	lbs	58.000	128,900

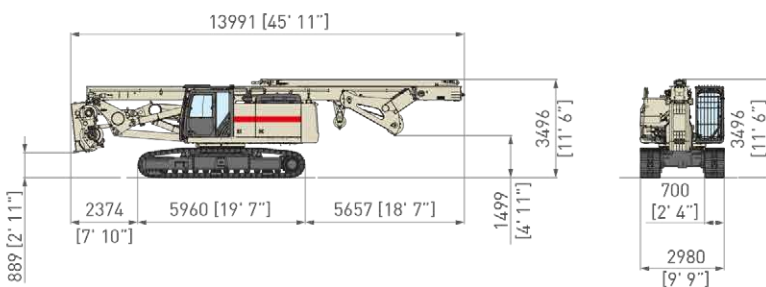

	m.s.	i.s.	CPD w/o mast foot	
Transport weight	kg	lbs	57.000	126,700

CH 650

Transport dimensions

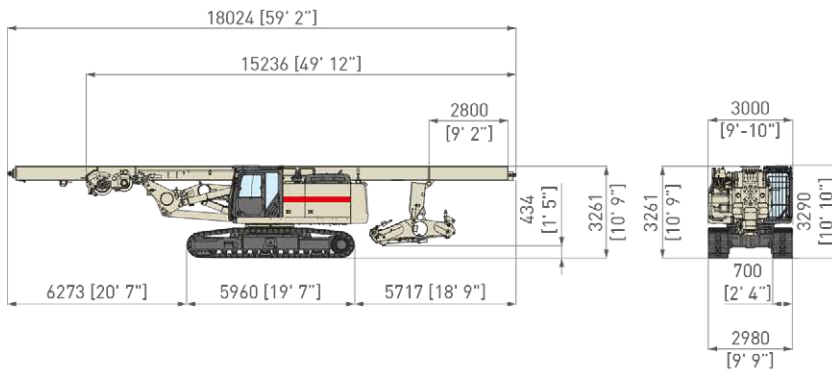

	m.s.	i.s.	CFA	
Transport weight	kg	lbs	59.500	132,200

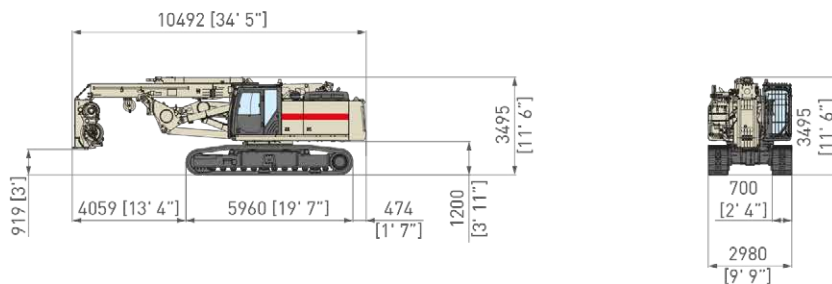

	m.s.	i.s.	LHR (short mast version)	
Transport weight	kg	lbs	53.600	119,100

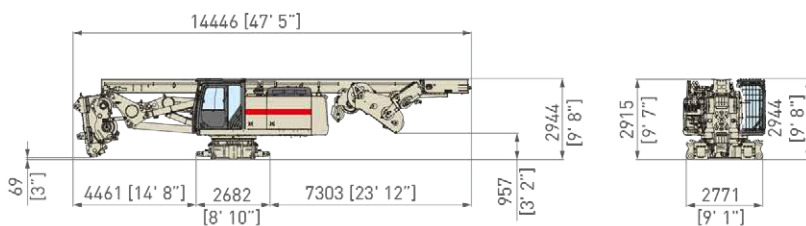

	m.s.	i.s.	WPD w/o mast foot w/o crawlers	
Transport weight	kg	lbs	44.900	99,800

Notes

All the weights refer to the machine with standard undercarriage; weights must be increased by 400 kg (880 lbs) if the undercarriage has removable tracks.
By removing the tracks the weight is reduced by 15.660 kg (34,400 lbs).



Comacchio S.p.A.

Via Callalta, 24/B - 31039 Riese Pio X (TV) (Italy)

Tel +39 0423 7585 - Fax + 39 0423 755592 - sales@comacchio.com