

### DH 16

#### Options Optionen

- > Hydraulic, electric or manual shifting  
Hydraulische, elektrische oder manuelle Schaltung
- > Mounting plates  
Montageplatten
- > Preventer system  
Preventersystem
- > Floating spindle  
Floating Spindel
- > Percussion unit type 40  
Schlagwerk Typ 40
- > Drilling accessories  
Bohrzubehör

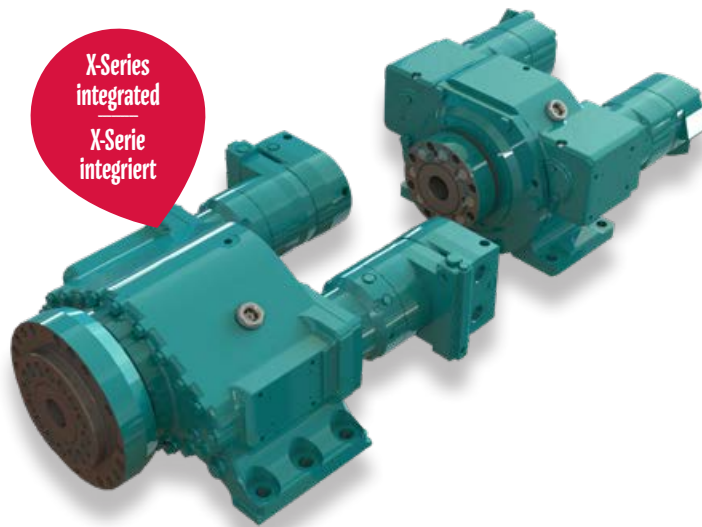

X-SERIES



VIBRATION HEADS



CORING HEADS



DOUBLE HEAD DRILLING SYSTEMS



ROTARY HEADS FOR PILE RIGS



DRILLING ACCESSORIES

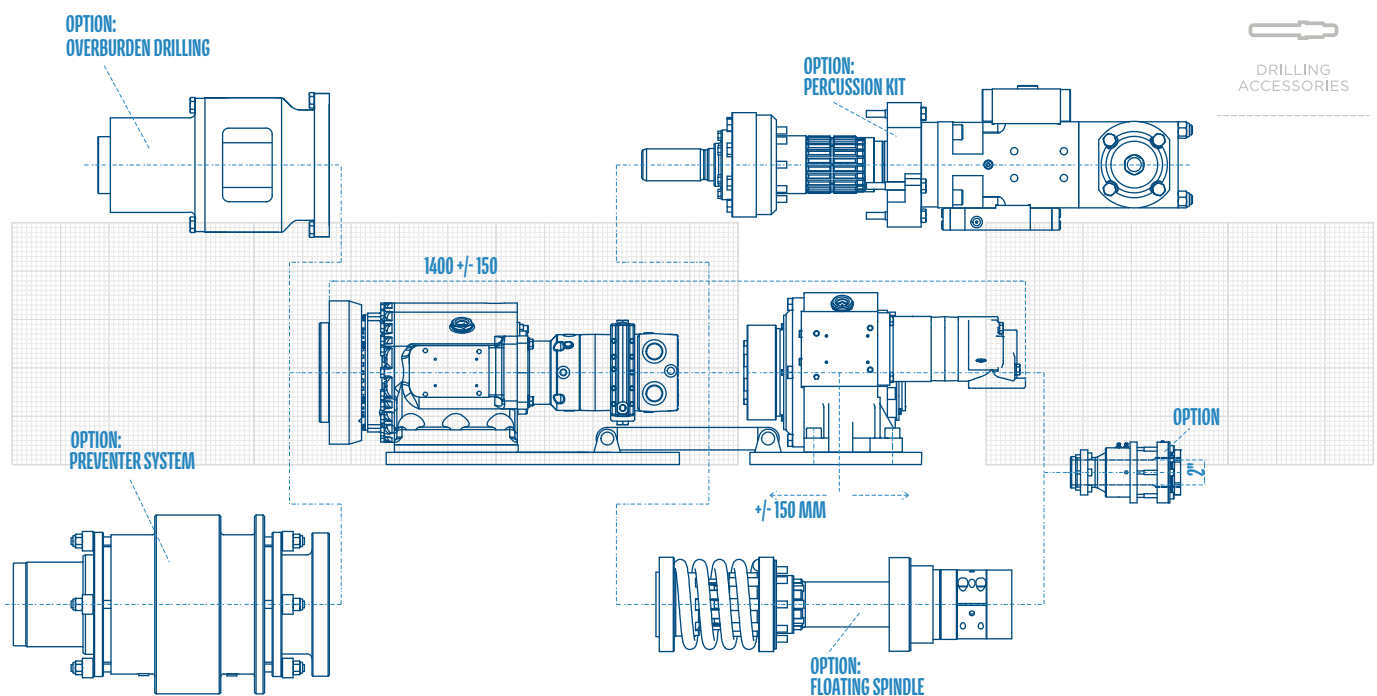

Technical Specifications are subject to modifications without prior notice and incurring responsibility for machines previously sold. The shown machines may have optional equipment. Technical data do not consider power losses. Error misprints reserved. / Technische Änderungen ohne Vorankündigung und Verpflichtung gegenüber früher gelieferten Geräten. Die abgebildeten Geräte können Sonderausstattungen haben. Technische Daten ohne Berücksichtigung des Wirkungsgrades. Irrtum und Druckfehler vorbehalten.



510 - 700 kg **Weight** Gewicht · 180 kN **Traction** Zugkraft

### Gear box 1 / Casing RH 16 X Getriebe 1 / Rohr

Motor Type Motor Typ Gear Gang	HP 48		HP 67	
	1	2	1	2
<b>Torque</b> Drehmoment	<b>11.6</b>	<b>5.8</b>	<b>16.2</b>	<b>8.1</b>
<b>Rotation</b> Drehzahl	<b>65</b>	<b>130</b>	<b>46</b>	<b>92</b>

p = 280 bar & Q = 170 l/min

### Gear box 2 / Inner rod RH 10 X Getriebe 2 / Innengestänge

Motor Type Motor Typ Gear Gang	96		97	
	1	2	1	2
<b>Torque</b> Drehmoment	<b>8.7</b>	<b>4.35</b>	<b>11</b>	<b>5.5</b>
<b>Rotation</b> Drehzahl	<b>55</b>	<b>110</b>	<b>43</b>	<b>86</b>

p = 250 bar & Q = 120 l/min

### Option percussion unit Option Schlagwerk

	Type Typ	40
<b>Operating pressure</b> Arbeitsdruck	bar	<b>160 - 200</b>
<b>Oil capacity</b> Ölmenge	l/min	<b>70 - 85</b>
<b>Single blow energy</b> Einzelschlagenergie	Nm	<b>... 500</b>
<b>No. of blows</b> Schlagfrequenz	min <sup>-1</sup>	<b>... 2400</b>