

# MC LINE

---

Foundation equipment



**COMACCHIO**

DRILLING HI-TECH

Con quasi 40 modelli di perforatrici dalle 2 alle 40 ton di peso, la linea MC offre la gamma più completa di perforatrici presente sul mercato in grado di coprire l'intero spettro di applicazioni legate all'ingegneria geotecnica. Ciascun modello si presta alle più svariate tipologie di perforazione a rotazione e rotopercolazione, con testa singola o doppia testa, e può essere configurato in funzione delle specifiche esigenze del cliente.

### Testa Singola



Rotazione



Rotopercolazione



Vibro - Rotazione

### Doppia Testa



Rotazione - Rotazione



Rotazione - Rotopercolazione



Rotazione - Vibro Rotazione

Le perforatrici della **linea MC** si avvantaggiano di una serie di soluzioni brevettate e incorporano sistemi altamente tecnologici, tra cui l'innovativo sistema di radiocomando Comacchio, l'esclusivo sistema di articolazione del mast e lo schermo protezione detriti, progettati per migliorare produttività, efficienza, sicurezza e comfort operativo. Le perforatrici MC "High Tech" Line, dotate di motori di nuova generazione EU Stage IV / US EPA Tier 4 Final, rappresentano il top della gamma, in grado di soddisfare i più alti standard ambientali.



### Perforatrici per spazi ridotti CON CENTRALE SEPARATA

Perforatrici compatte dalle 3 alle 8 tonnellate di peso, dotate di centrale idraulica separata (diesel o elettrica) e caratterizzate da una grande varietà di posizionamenti e inclinazioni del mast, progettate per operare all'interno di spazi angusti e di difficile accesso.

#### LIMITED ACCESS Rigs with Remote Power Pack

Compact drill rigs ranging from 3 to 8 tonnes weight with remote diesel (or electric) hydraulic power packs. Flexible mast positioning for both vertical and inclined drilling, suited for both indoor and outside operations, low clearance and limited access job sites.

MC 2D - MC 3D - MC 4D  
MC 5D - MC 8D



### Perforatrici ARTICOLATE MULTIFUNZIONE

Perforatrici caratterizzate da una grande versatilità e produttività, con un range di potenza da 75 a 205 kW in una gamma di peso dalle 6 alle 30 ton. Grazie al sistema brevettato di articolazione del mast queste macchine sono in grado di coprire l'intero spettro di lavorazioni legate alle opere speciali di fondazione e consolidamento dei terreni, tra cui micropali, ancoraggi, soil nailing e jet grouting.

#### FULLY ARTICULATED MULTIPURPOSE Rigs

Extremely versatile and powerful drill rigs ranging from 6 to 30 tonnes and from 75 to 205 kW in power, featuring the Comacchio patented fully articulated mast design system and suitable for the full range of geotechnical applications including micropiles, anchors, soil nails and jet grouting.

MC 3 - MC 6 - MC 8 - MC 12 - MC 14  
MC 15 - MC 15 P - MC 20 - MC 22  
MC 22 A - MC 28 - MC 28 HD  
MC 28 A HD



### Perforatrici VERTICALI MULTIFUNZIONE

Perforatrici multifunzione con range di potenza da 75 a 205 kW in una gamma di peso da 6 a 40 ton, dotate di cinematismo verticale che garantisce rigidità e precisione nel posizionamento anche con corse lunghe, studiate per affrontare applicazioni verticali (installazione di micropali) con l'utilizzo di metodi altamente produttivi, tra cui jet grouting e mini-piling con eliche o con metodo CFA (allestimento "F").

#### VERTICAL MULTIPURPOSE Rigs

Multipurpose heavy-duty drill rigs that range from 6 to 40 tonnes and have power-packs delivering 75 to 205 kW, featuring a long feed stroke, robust mast design for vertical applications, supporting highly productive methods of micropile and mini-pile installations, including jet grouting and augering with solid or hollow bore CFA augers (F-configuration).

MC 4 - MC 6V - MC 10  
MC 13 - MC 21 - MC 24  
MC 30 - MC 40

## THE WINNING SOLUTION FOR A SOLID FOUNDATION

# MC LINE

With almost 40 models ranging from 2 to 40 tons, the Comacchio **MC line** offers the industry's most comprehensive line up of drilling machines that cover the entire range of ground engineering applications. Each rig can be used for rotary and rotary-percussive drilling, for single head or double head applications. Comacchio drills can be tailored to meet your specific requirements.

### Single Head



Rotary drilling



Rotary - percussive



Vibro - Rotary

### Double Head



Rotary - Rotary



Rotary - Percussive



Rotary vibro drilling

**MC line** rigs take advantage of exclusive patented solutions that offer a number of high tech features, including Comacchio's state-of-the-art radio remote control system, mast articulations that allow the mast slew through 180 degrees without re-pinning the cylinders and cuttings protection screens to control cuttings when using double tube systems – all this improves productivity, efficiency, safety and operator comfort. To meet the highest environmental standards the MC "High Tech" Line is engineered to incorporate latest generation EU Stage IV / US EPA Tier 4 Final engines.

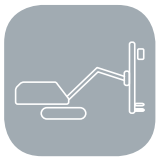

### Perforatrici Multifunzione A SBRACCIO LUNGO

Perforatrici con articolazione del mast di tipo "long reach" (a sbraccio lungo) che garantisce ampi raggi di lavoro in condizioni di spazi ristretti e di difficile accesso, ideali per l'esecuzione di opere di consolidamento o di sostegno di pareti e fronti di scavo con tecniche di perforazione a rotazione o roto-percussione e in particolare con l'uso di sistemi a barre autopercoranti.

### LONG REACH Multipurpose Rigs

Compact drill rigs featuring a double boom "long reach" mast design to handle restricted or difficult site locations, ideally suited for anchored retaining walls and slope stabilization, soil nailing using both rotary and rotary-percussive drilling techniques, in particular, self-drilling hollow bar systems.

**MC 9 - MC 10 ES**



### Mast per Escavatori MC-E

Mast di perforazione applicati su escavatori, progettati per affrontare situazioni di lavoro particolari, dove le condizioni e gli spazi di lavoro impediscono l'uso di una macchina perforatrice cingolata convenzionale.

### MC-E Drilling Attachments

Excavator boom mounted drilling masts for special operations in limited and open job/sites, reaching over obstacles and operating on slopes. This low bearing pressure equipment is the the answer where traditional crawler drills can't be used.

**MC-E 12 - MC-E 25  
MC-E 30 - MC-E 40  
MC-E 45 - MC-E 60  
MC-E 80 - MC-E 100**



### Posizionatore per GALLERIA

Posizionatori utilizzati per opere di impermeabilizzazione e consolidamento del terreno legate alla realizzazione di gallerie, compresa l'installazione di micropali sub-orizzontali (ombrello), interventi di jet grouting o altre tecniche di iniezione. La MC 30 TX, in particolare, può essere convertita in una perforatrice standard articolata.

### TUNNELING Rigs

Drilling rigs used for waterproofing and ground improvement works in tunnel construction projects, including forepoling applications (umbrella drilling), jet grouting and other injection grouting applications. The MC 30 TX can be also converted into a standard fully articulated micro piling machine.

**MC 30 TX**



### Perforatrici e Attrezzature SPECIALI

Soluzioni tecniche e attrezzature speciali altamente personalizzate progettate e realizzate per soddisfare esigenze specifiche e affrontare lavorazioni particolari.

### SPECIAL Rigs and Equipment

Engineered solutions and individually customised special purpose drill machines designed for specific requirements, tailored to meet our customer's need and to carry out particular drilling tasks.





**MC-S**

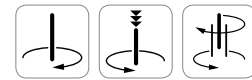
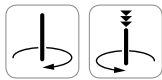
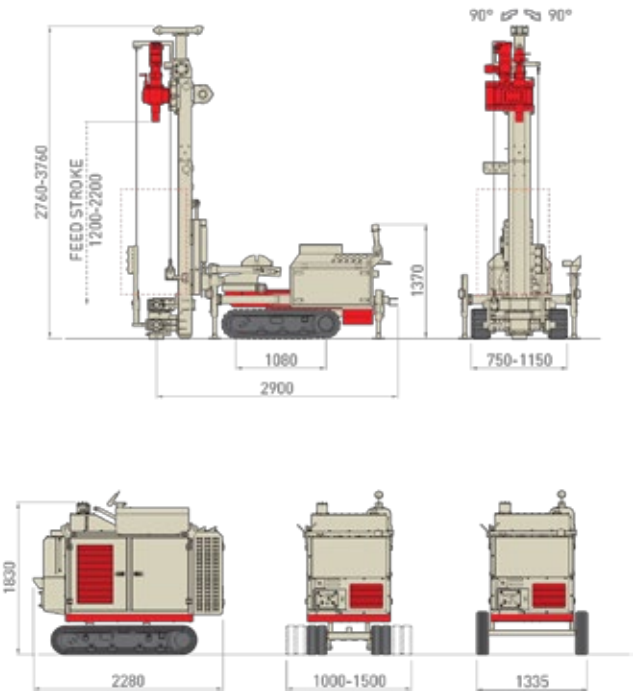
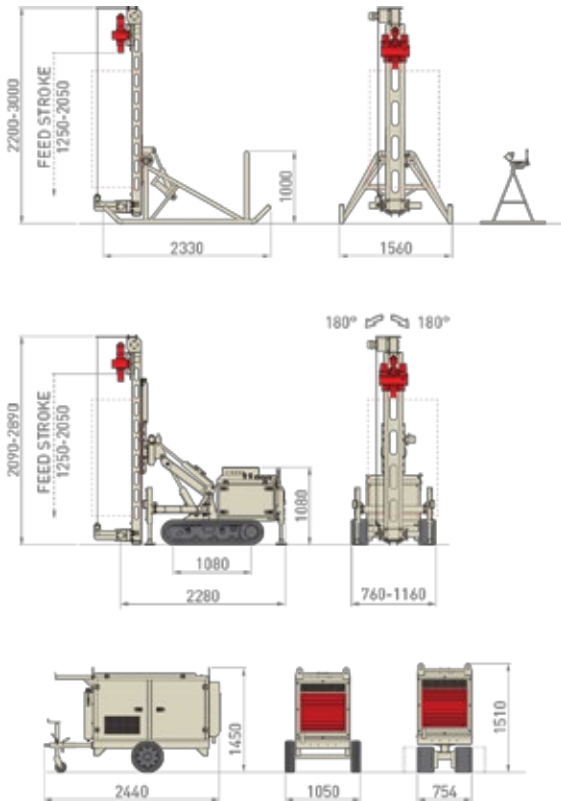

# MC 2D

# MC 3D



	 		  			
			m.s.	i.s.		
Potenza Motore Engine Power	33	44	kW	HP	33 - 55	44 - 74
Livello Emissioni Emission Level	Step 3A / Tier 4i		-		Step 3A / Tier 4i - Step 3B / Tier 4 (HT Line)	
Motore Elettrico Electric Motor	30	40	kW	HP	30 - 55	40 - 74
Corsa Mast Mast Feed Stroke	1.250 - 2.050	4.1 - 6.7	mm	ft	1.200 - 2.200	3.9 - 7.2
Forza di Spinta Feed Force	1.200	2,697	daN	lbs	2.500	5,620
Forza di Tiro Retract Force	1.200	2,697	daN	lbs	2.500	5,620
Coppia Rotary Rotary Torque Range	200 - 480	1,475 - 3,540	daNm	lb*ft	200 - 510	1,475 - 3,761
Giri Rotary Rotary Speed Range	80 - 580		rpm		80 - 560	
Serraggio Morse Clamp Range	45 - 185	1.8 - 7.3	mm	in	45 - 220	1.8 - 8.6
Peso Performatrice Rig Weight	600 - 1.500	1,300 - 3,300	kg	lbs	2.600 - 3.100	5,700 - 6,800
Peso Centrale Power Pack Weight	1.000	2,200	kg	lbs	1.000 - 2.300	2,200 - 5,000



# MC 4D

# MC 5D

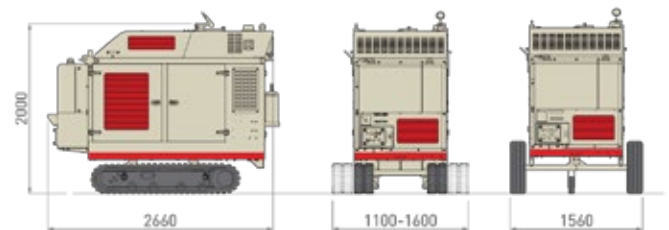
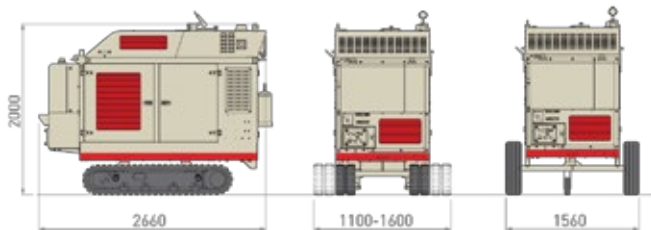
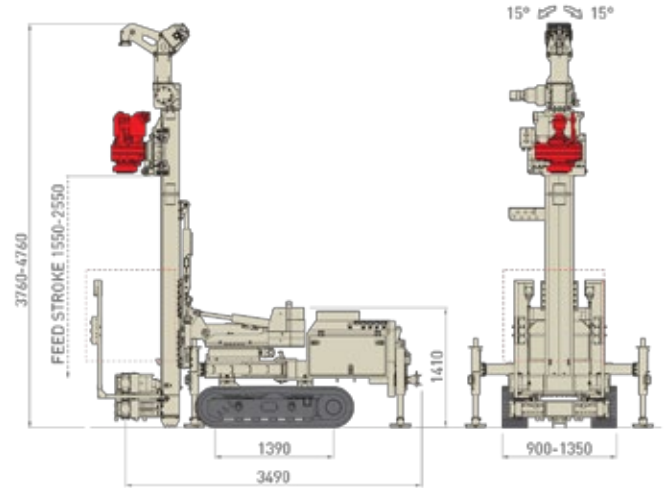
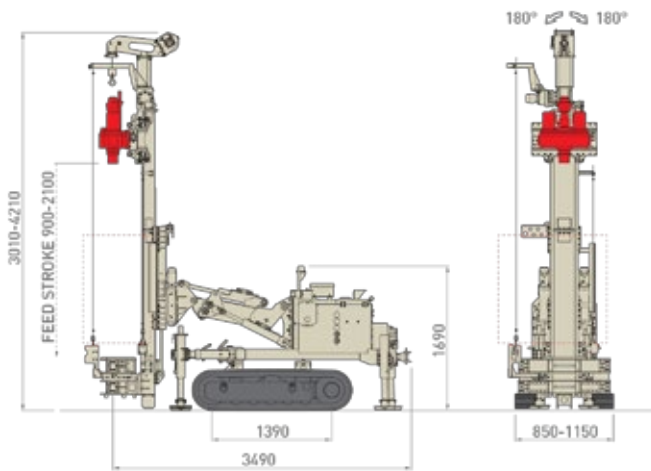

m.s. i.s.

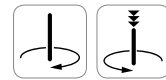

Potenza Motore Engine Power	55 - 100	74 - 134	kW	HP	86 - 100	115 - 134
Livello Emissioni Emission Level	Step 3A / Tier 3 - <b>Step 4 / Tier 4f (HT Line)</b>		-		Step 3A / Tier 3 - <b>Step 4 / Tier 4f (HT Line)</b>	
Motore Elettrico Electric Motor	55 - 75	74 - 100	kW	HP	75	100
Corsa Mast Mast Feed Stroke	943 - 2.100	3.1 - 6.9	mm	ft	950 - 2.550	3.1 - 8.4
Forza di Spinta Feed Force	3.500	7,868	daN	lbs	3.300 - 5.500	7,418 - 12,364
Forza di Tiro Retract Force	3.500	7,868	daN	lbs	4.500 - 5.500	10,116 - 12,364
Coppia Rotary Rotary Torque Range	450 - 1.550	3,319 - 11,432	daNm	lb*ft	450 - 2.325	3,319 - 17,148
Giri Rotary Rotary Speed Range	65 - 380		rpm		80 - 380	
Serraggio Morse Clamp Range	45 - 325	1.8 - 12.8	mm	in	45 - 360	1.8 - 14.2
Peso Perforatrice Rig Weight	4.600 - 5.200	10,100 - 11,500	kg	lbs	5.300 - 5.800	11,700 - 12,800
Peso Centrale Power Pack Weight	2.000 - 2.800	4,400 - 6,100	kg	lbs	2.100 - 2.800	4,600 - 6,100





# MC 8D

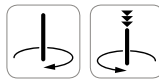
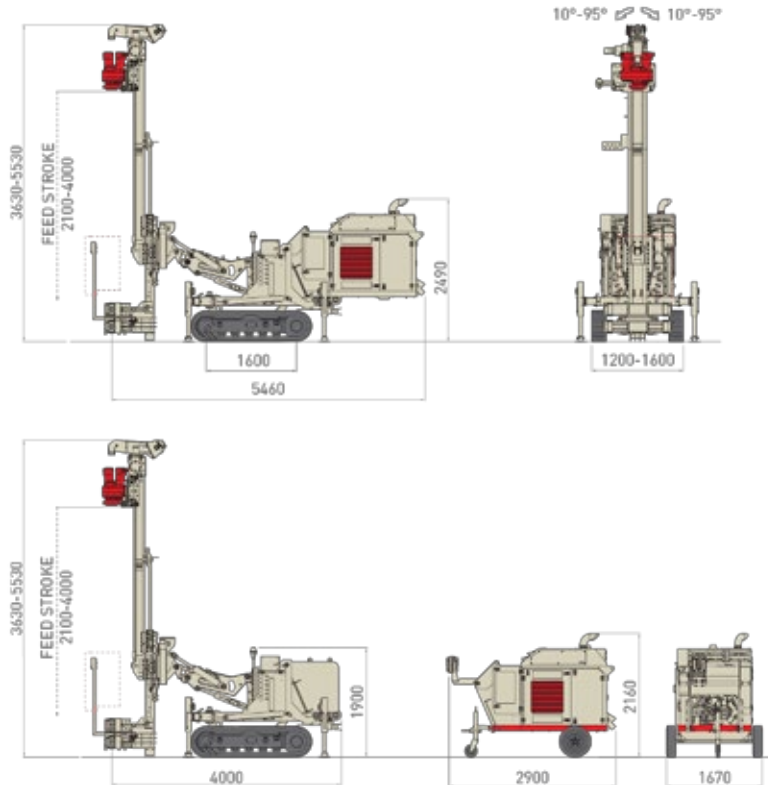

	m.s.	i.s.		
Potenza Motore Engine Power	kW	HP	97	130
Livello Emissioni Emission Level	<b>Step 4 / Tier 4f (HT Line)</b>			
Motore Elettrico Electric Motor	kW	HP	75	100
Corsa Mast Mast Feed Stroke	mm	ft	950 - 4.000	3.1 - 13.1
Forza di Spinta Feed Force	daN	lbs	5.500	12,364
Forza di Tiro Retract Force	daN	lbs	5.500	12,364
Coppia Rotary Rotary Torque Range	daNm	lb*ft	450 - 2.325	3,319 - 17,148
Giri Rotary Rotary Speed Range	rpm		70 - 380	
Serraggio Morse Clamp Range	mm	in	45 - 360	1.8 - 14.2
Peso Weight	kg	lbs	9.100 - 9.600	20,000 - 21,000





## Perforatrici **ARTICOLATE MULTIFUNZIONE** **FULLY ARTICULATED MULTIPURPOSE Rigs**



Perforatrici caratterizzate da una grande versatilità e produttività, con un range di potenza da 75 a 205 kW in una gamma di peso dalle 6 alle 30 ton. Grazie al sistema brevettato di articolazione del mast queste macchine sono in grado di coprire l'intero spettro di lavorazioni legate alle opere speciali di fondazione e consolidamento dei terreni, tra cui micropali, ancoraggi, soil nailing e jet grouting.

*Extremely versatile and powerful drill rigs ranging from 6 to 30 tonnes and from 75 to 205 kW in power, featuring the Comacchio patented fully articulated mast design system and suitable for the full range of geotechnical applications including micropiles, anchors, soil nails and jet grouting.*



# MC 3

# MC 6

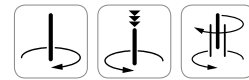
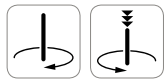
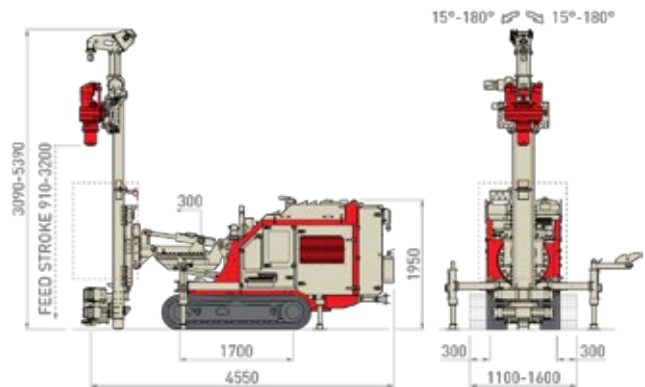
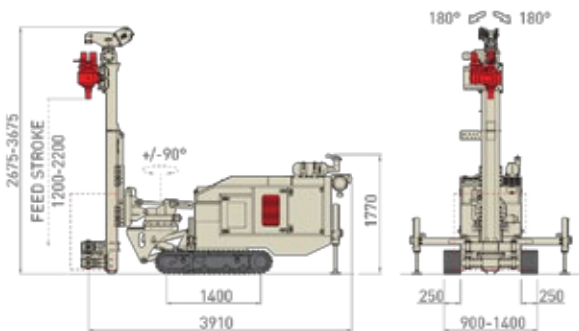

	Step 3B / Tier 4 (HT Line)		Step 4 / Tier 4f (HT Line)	
Potenza Motore Engine Power	55	74	100	134
Livello Emissioni Emission Level	Step 3B / Tier 4 (HT Line)		Step 4 / Tier 4f (HT Line)	
Motore Elettrico Electric Motor	-		75	100
Corsa Mast Mast Feed Stroke	1.200 - 2.200	3.9 - 7.2	943 - 3.200	3.1 - 10.5
Forza di Spinta Feed Force	2.500	5,620	5.000	11,240
Forza di Tiro Retract Force	2.500	5,620	5.000	11,240
Coppia Rotary Rotary Torque Range	200 - 510	1,475 - 3,761	450- 1.550	3,319 - 11,432
Giri Rotary Rotary Speed Range	80 - 560		80 - 380	
Serraggio Morse Clamp Range	45 - 220	1.8 - 8.6	45 - 325	1.8 - 12.8
Peso Weight	3.200 - 3.500	7,000 - 7,700	6.200 - 6.800	13,700 - 15,000

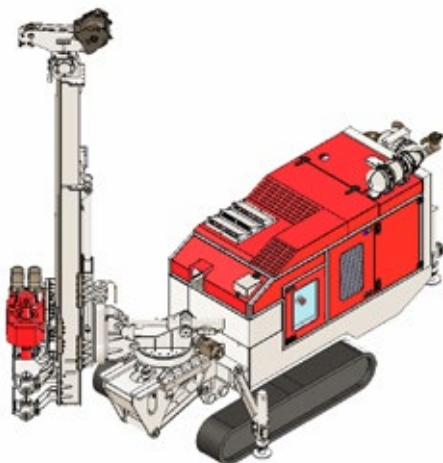



# MC 8

# MC 12

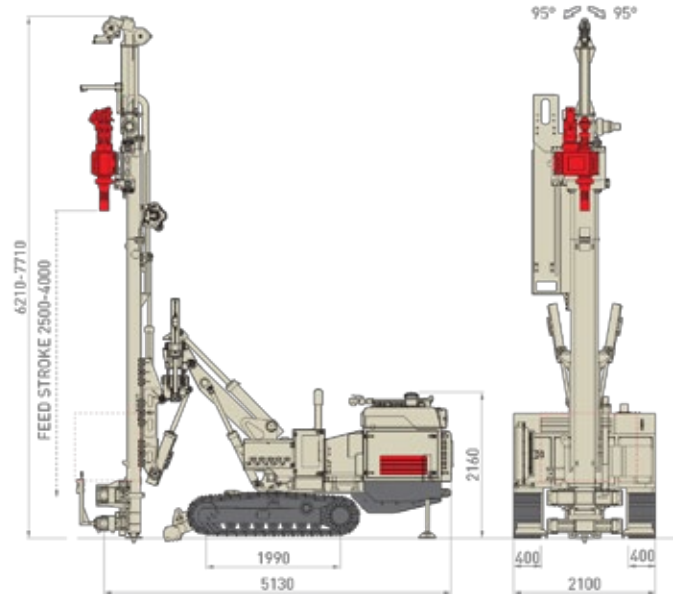
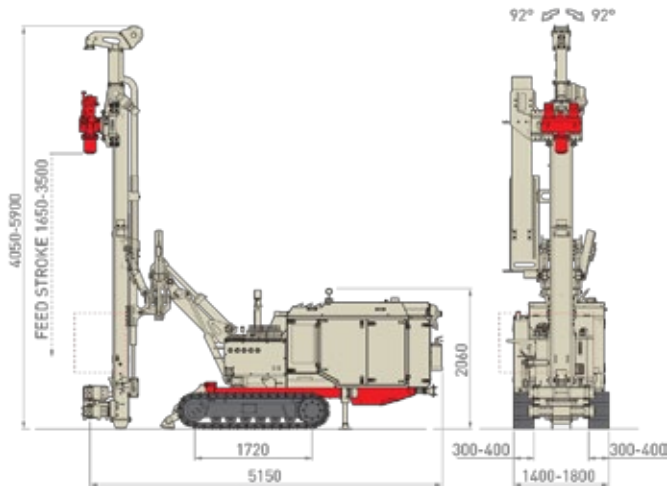

			m.s.	i.s.		
Potenza Motore Engine Power	86 - 100	115 - 134	kW	HP	95 - 115	127 - 154
Livello Emissioni Emission Level	Step 3A / Tier 3 - Step 4 / Tier 4f (HT Line)		-		Step 3A / Tier 3 - Step 4 / Tier 4f (HT Line)	
Motore Elettrico Electric Motor	-		kW	HP	-	
Corsa Mast Mast Feed Stroke	1.650 - 3.900	5.4 - 12.8	mm	ft	2.500 - 4.000	8.2 - 13.1
Forza di Spinta Feed Force	5.000	11,240 lbs	daN	lbs	5.500	12,364 lbs
Forza di Tiro Retract Force	5.000	11,240 lbs	daN	lbs	5.500	12,364 lbs
Coppia Rotary Rotary Torque Range	450 - 1.550	3,319 - 11,432 lb*ft	daNm	lb*ft	450 - 2.325	3,319 - 17,148
Giri Rotary Rotary Speed Range	70 - 750		rpm		80 - 290	
Serraggio Morse Clamp Range	45 - 325	1.8 - 12.8	mm	in	45 - 420	1.8 - 16.5
Peso Weight	8.200 - 8.900	18,000 - 19,600	kg	lbs	11.500 - 13.500	25,300 - 29,700





# MC 14

# MC 15

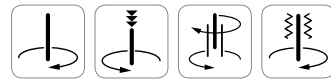
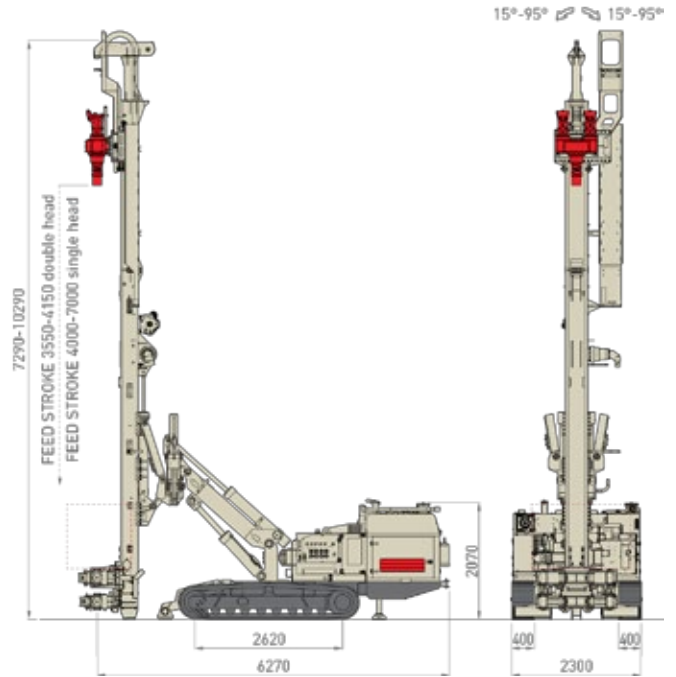
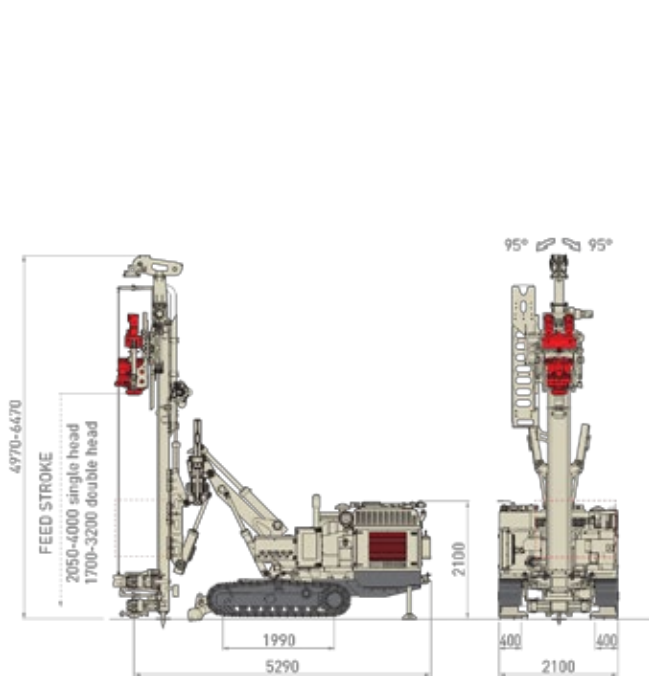

	m.s.		i.s.	
Potenza Motore Engine Power	129	173	kW	HP
Livello Emissioni Emission Level	Step 4 / Tier 4f (HT Line)		Step 3A / Tier 3 - Step 4 / Tier 4f (HT Line)	
Corsa Mast Mast Feed Stroke	1.700 - 4.000	5.6 - 13.1	mm	ft
Forza di Spinta Feed Force	5.500	12,364	daN	lbs
Forza di Tiro Retract Force	5.500	12,364	daN	lbs
Coppia Rotary Rotary Torque Range	1.000 - 2.325	7,375 - 17,148	daNm	lb*ft
Giri Rotary Rotary Speed Range	80 - 290		rpm	
Serraggio Morse Clamp Range	45 - 360	1.8 - 14.2	mm	in
Peso Weight	13.000 - 15.000	28,700 - 33,100	kg	lbs



# MC 15 P

# MC 20

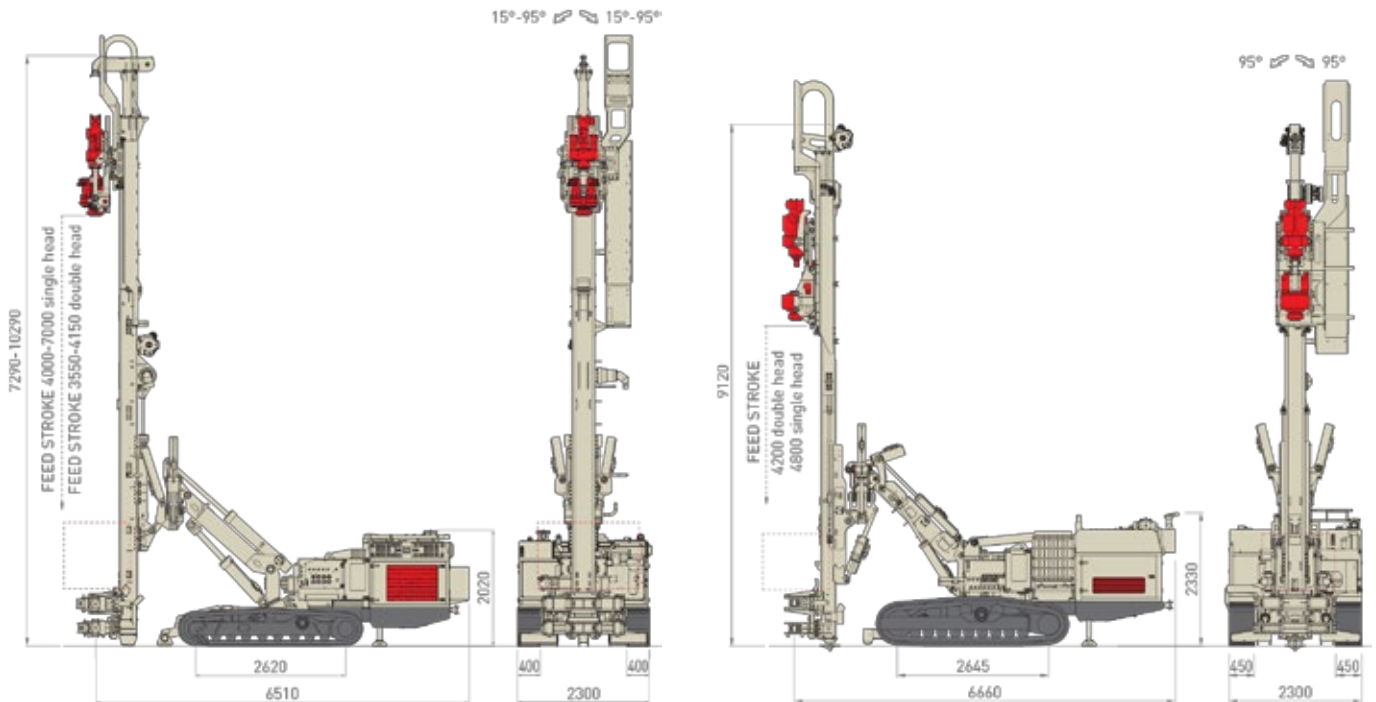

	Step 4 / Tier 4f (HT Line)		-		Step 3A / Tier 3 - Step 4 / Tier 4f (HT Line)	
Potenza Motore Engine Power	168	225	kW	i.s.	188 - 205	252 - 275
Livello Emissioni Emission Level	Step 4 / Tier 4f (HT Line)		-		Step 3A / Tier 3 - Step 4 / Tier 4f (HT Line)	
Corsa Mast Mast Feed Stroke	3.550 - 7.000	11.6 - 22.9	mm	ft	4.200 - 4.800	13.7 - 15.7
Forza di Spinta Feed Force	8.000	17,984	daN	lbs	9.500	21,357
Forza di Tiro Retract Force	8.000	17,984	daN	lbs	9.500	21,357
Coppia Rotary Rotary Torque Range	1.000 - 3.100	7,375 - 22,864	daNm	lb*ft	1.500 - 3.600	11,069 - 26,552
Giri Rotary Rotary Speed Range	80 - 260		rpm		80 - 290	
Serraggio Morse Clamp Range	45 - 520	1.8 - 20.5	mm	in	45 - 420	1.8 - 16.5
Peso Weight	16.500 - 18.500	31,900 - 40,700	kg	lbs	19.500 - 21.500	42,900 - 47,400





# MC 22

# MC 22 A

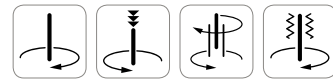
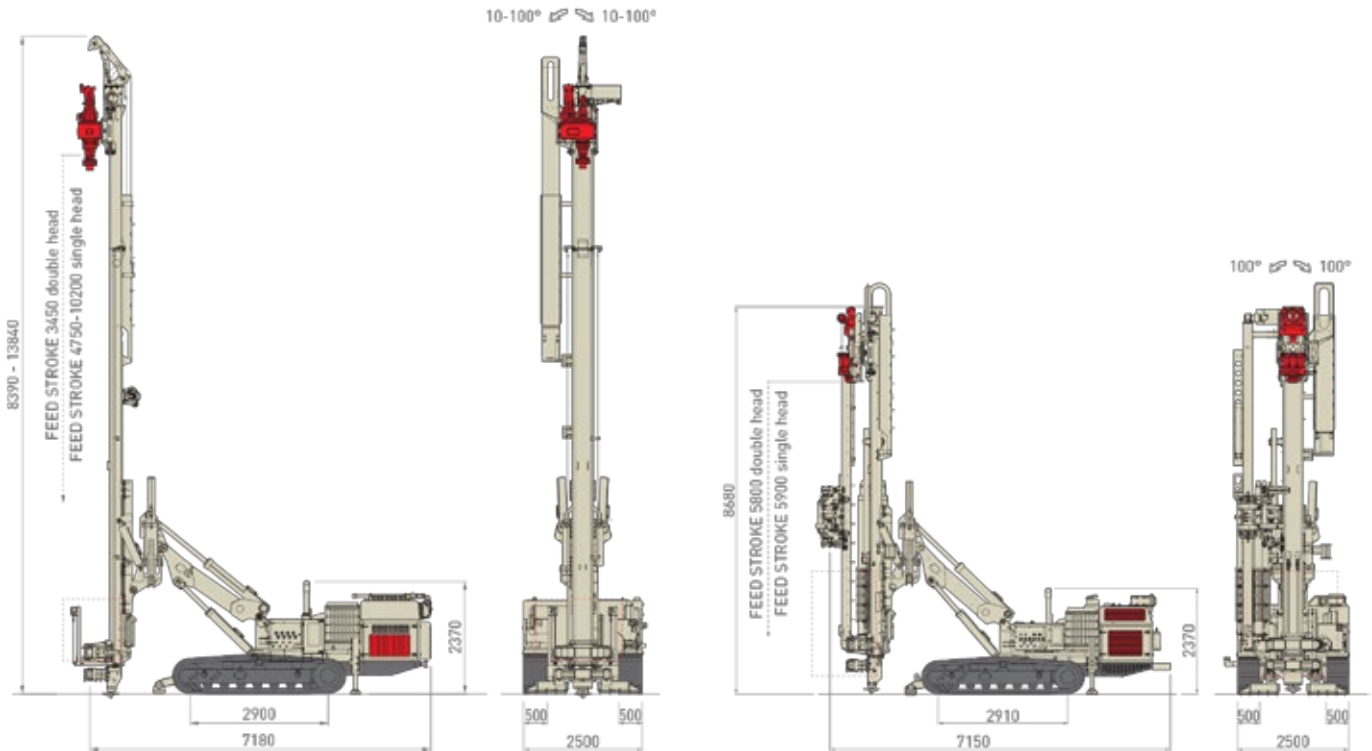

	MC 22		MC 22 A	
Potenza Motore Engine Power	147 - 168	197 - 225	kW	HP
Livello Emissioni Emission Level	Step 3A / Tier 3 - <b>Step 4 / Tier 4f (HT Line)</b>		Step 3A / Tier 3 - <b>Step 4 / Tier 4f (HT Line)</b>	
Corsa Mast Mast Feed Stroke	3.450 - 10.200	11.3 - 33.5	mm	ft
Forza di Spinta Feed Force	8.000	17,984	daN	lbs
Forza di Tiro Retract Force	8.000	17,984	daN	lbs
Coppia Rotary Rotary Torque Range	1.300 - 3.100	9,588 - 22,864	daNm	lb*ft
Giri Rotary Rotary Speed Range	70 - 350		rpm	
Serraggio Morse Clamp Range	45 - 520	1.8 - 20.5	mm	in
Peso Weight	22.000 - 24.000	48,500 - 52,900	kg	lbs

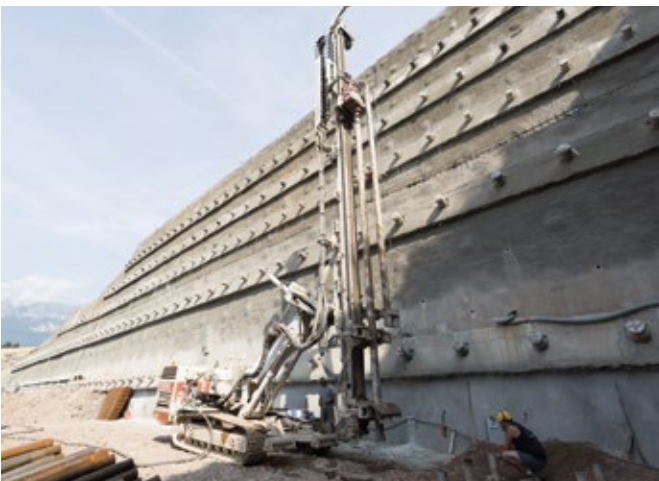

# MC 28

# MC 28 HD

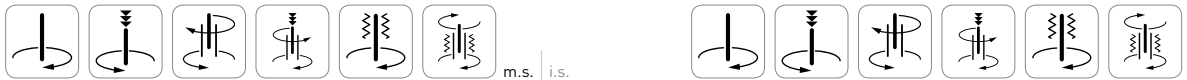
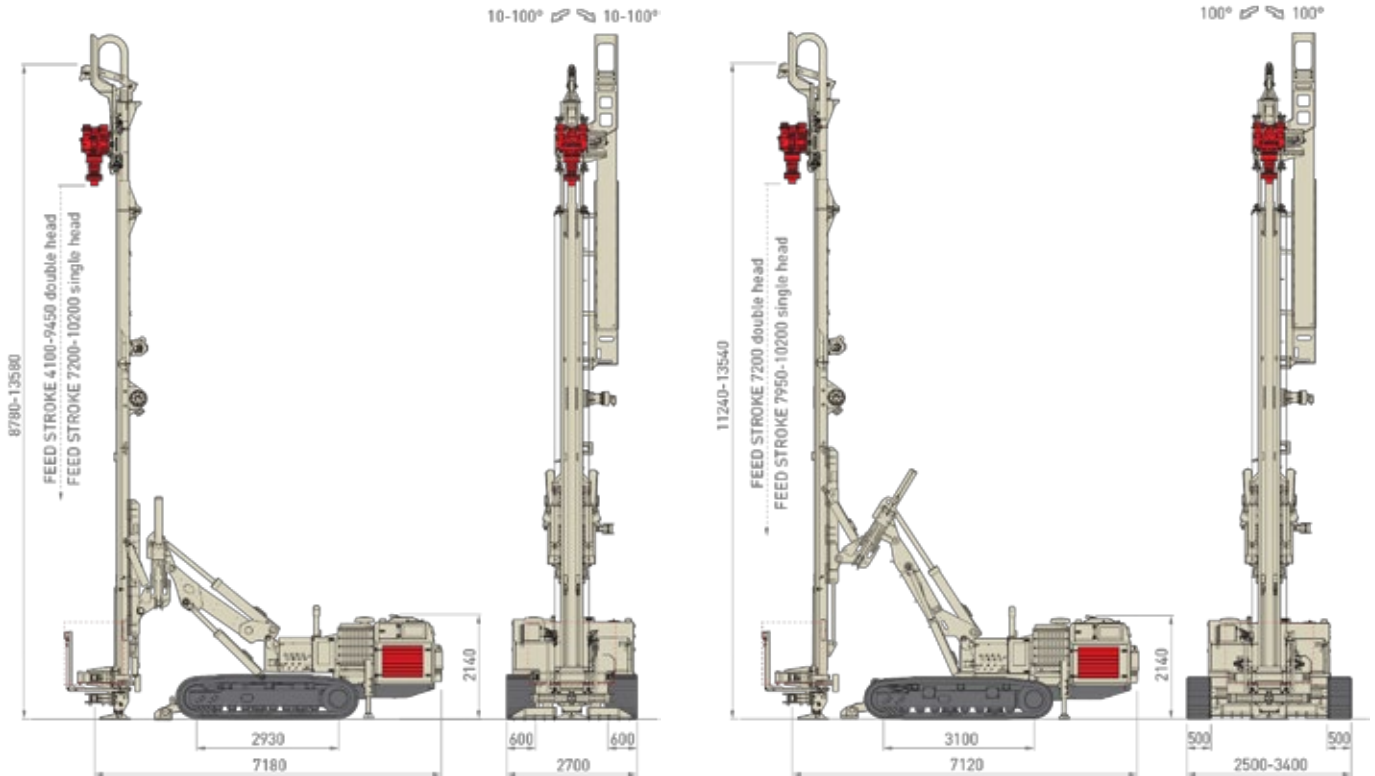

Potenza Motore Engine Power	188 - 205	252 - 275	kW	HP	205	275
Livello Emissioni Emission Level	Step 3A / Tier 3 - Step 4 / Tier 4f (HT Line)		-			
Corsa Mast Mast Feed Stroke	4.100 - 10.200	13.4 - 33.5	mm	ft	7.200 - 10.200	23.6 - 33.4
Forza di Spinta Feed Force	9.500 - 14.000	21,357 - 31,473	daN	lbs	14.000	31,473
Forza di Tiro Retract Force	9.500 - 14.000	21,357 - 31,473	daN	lbs	14.000	31,473
Coppia Rotary Rotary Torque Range	2.400 - 5.500	17,701 - 40,565	daNm	lb*ft	2.400 - 5.500	17,701 - 40,565
Giri Rotary Rotary Speed Range	50 - 210		rpm		50 - 210	
Serraggio Morse Clamp Range	45 - 520	1.8 - 20.5	mm	in	45 - 420	1.8 - 16.5
Peso Weight	26.000 - 28.000	57,300 - 61,700	kg	lbs	29.000 - 30.000	63,900 - 66,100





# MC 28 A HD

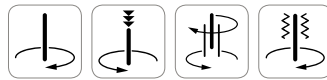
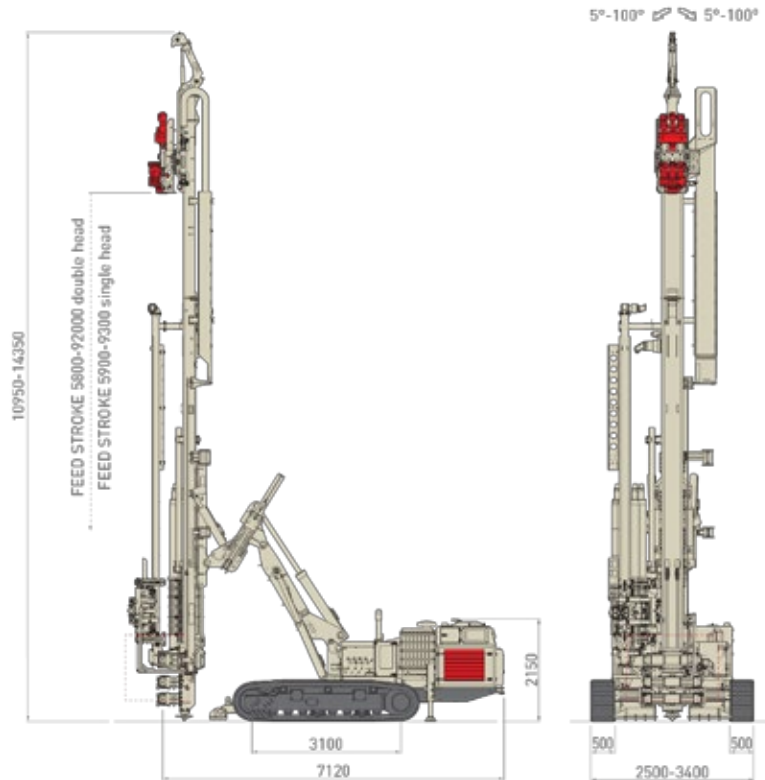

	m.s.	i.s.		
Potenza Motore Engine Power	kW	HP	205	275
Livello Emissioni Emission Level	<b>Step 4 / Tier 4f (HT Line)</b>			
Corsa Mast Mast Feed Stroke	mm	ft	5.800 - 9.300	19.0 - 30.5
Forza di Spinta Feed Force	daN	lbs	9.500	21,357
Forza di Tiro Retract Force	daN	lbs	9.500	21,357
Coppia Rotary Rotary Torque Range	daNm	lb*ft	1.500 - 5.500	11,063 - 40,565
Giri Rotary Rotary Speed Range	rpm		50 - 260	
Serraggio Morse Clamp Range	mm	in	45 - 360	1.8 - 14.2
Peso Weight	kg	lbs	29.000 - 31.000	63,900 - 68,300





## Perforatrici **VERTICALI MULTIFUNZIONE** **VERTICAL MULTIPURPOSE** Rigs



Perforatrici multifunzione con range di potenza da 75 a 205 kW in una gamma di peso da 6 a 40 ton, dotate di mast a corsa lunga studiato per garantire rigidità e precisione nel posizionamento e affrontare applicazioni verticali (installazione di micropali) con l'utilizzo di metodi altamente produttivi, tra cui jet grouting e mini-piling con eliche o con metodo CFA (allestimento "F").

*Multipurpose heavy-duty drill rigs that range from 6 to 40 tonnes and have power-packs delivering 75 to 205 kW, featuring a long feed stroke, robust mast, design for vertical applications, supporting highly productive methods of micropile and mini-pile installations, including jet grouting and augering with solid or hollow bore CFA augers (F-configuration).*



# MC 4

# MC 6V

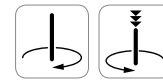
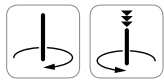
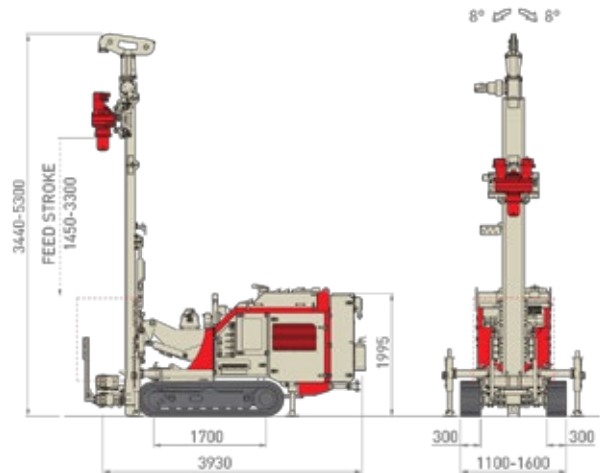
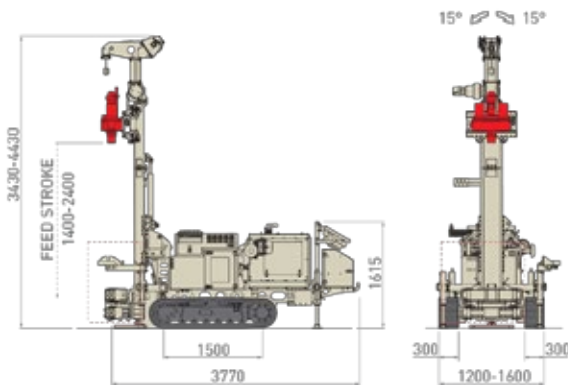

	Step 3B / Tier 4 (HT Line)		m.s.		i.s.	
Potenza Motore Engine Power	55	74	kW	HP	100	134
Livello Emissioni Emission Level	Step 3B / Tier 4 (HT Line)		-		Step 4 / Tier 4f (HT Line)	
Corsa Mast Mast Feed Stroke	1.400 - 2.400	4.6 - 7.8	mm	ft	1.450 - 3.300	4.7 - 10.8
Forza di Spinta Feed Force	5.000	11,240	daN	lbs	5.000	11,240
Forza di Tiro Retract Force	5.000	11,240	daN	lbs	5.000	11,240
Coppia Rotary Rotary Torque Range	450 - 1.550	3,319 - 11,432	daNm	lb*ft	450 - 2.325	3,319 - 17,148
Giri Rotary Rotary Speed Range	60 - 170		rpm		80 - 210	
Serraggio Morse Clamp Range	45 - 325	1.8 - 12.8	mm	in	45 - 325	1.8 - 12.8
Peso Weight	4.000 - 4.500	8,800 - 9,900	kg	lbs	5.800 - 6.000	12,700 - 13,200



© Roger Bullivant Limited



# MC 10

# MC 13

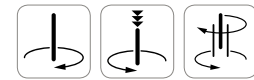
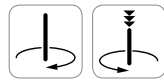
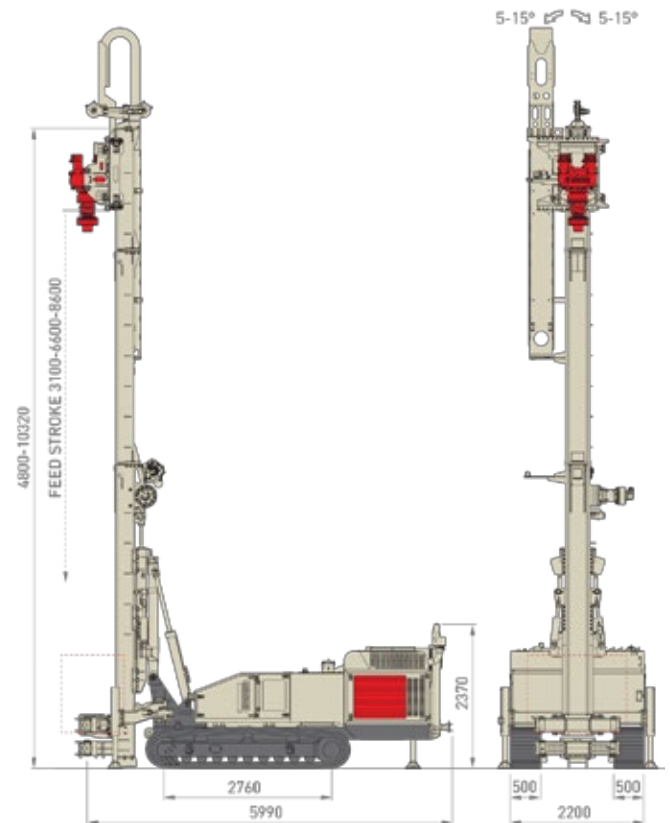
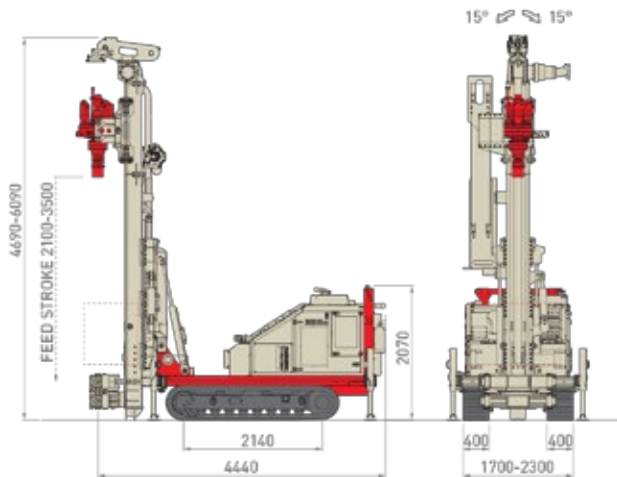

	MC 10		MC 13	
Potenza Motore Engine Power	115	154	m.s. kW	i.s. HP
Livello Emissioni Emission Level	Step 4 / Tier 4f (HT Line)		-	
Corsa Mast Mast Feed Stroke	2.100 - 3.500	6.8 - 11.4	mm	ft
Forza di Spinta Feed Force	8.000	17,984	daN	lbs
Forza di Tiro Retract Force	8.000	17,984	daN	lbs
Coppia Rotary Rotary Torque Range	1.000 - 3.100	7,375 - 22,864	daNm	lb*ft
Giri Rotary Rotary Speed Range	40 - 290		rpm	
Serraggio Morse Clamp Range	45 - 360	1.8 - 14.1	mm	in
Peso Weight	10.000 - 11.000	22,000 - 24,000	kg	lbs





# MC 21

# MC 24

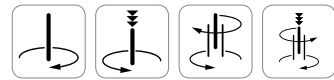
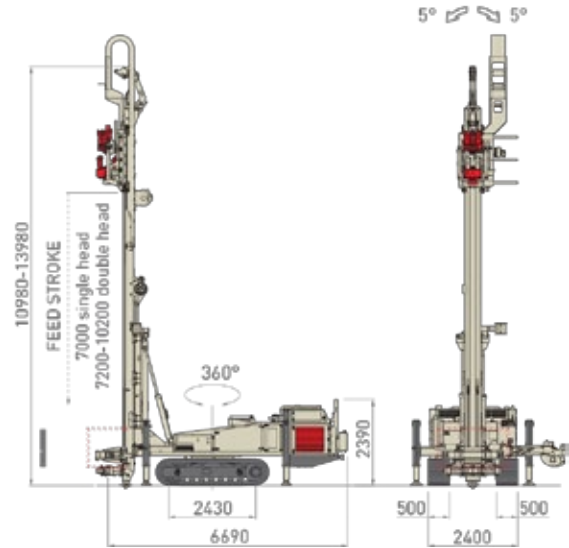
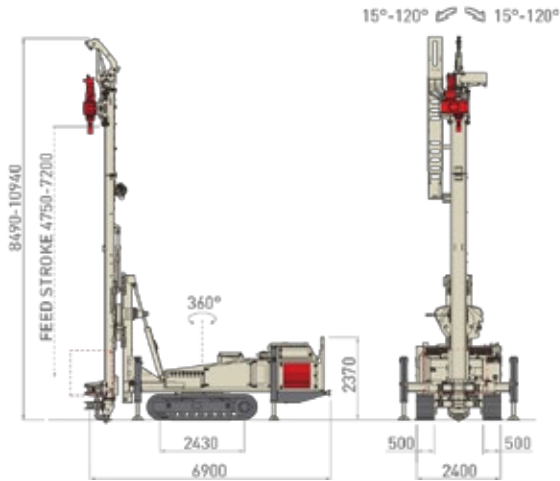

	MC 21		MC 24	
	m.s.	i.s.	m.s.	i.s.
Potenza Motore Engine Power	168	225	kW	HP
Livello Emissioni Emission Level	<b>Step 4 / Tier 4f (HT Line)</b>		<b>Step 4 / Tier 4f (HT Line)</b>	
Corso Mast Mast Feed Stroke	3.450 - 7.200	11.3 - 23.6	mm	ft
Forza di Spinta Feed Force	8.000	17,984	daN	lbs
Forza di Tiro Retract Force	8.000	17,984	daN	lbs
Coppia Rotary Rotary Torque Range	1.300 - 3.100	9,588 - 22,864	daNm	lb*ft
Giri Rotary Rotary Speed Range	50 - 350		rpm	
Serraggio Morse Clamp Range	45 - 360	1.8 - 14.1	mm	in
Peso Weight	21.000 - 22.000	46,300 - 48,500	kg	lbs



# MC 30

# MC 40

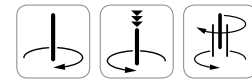
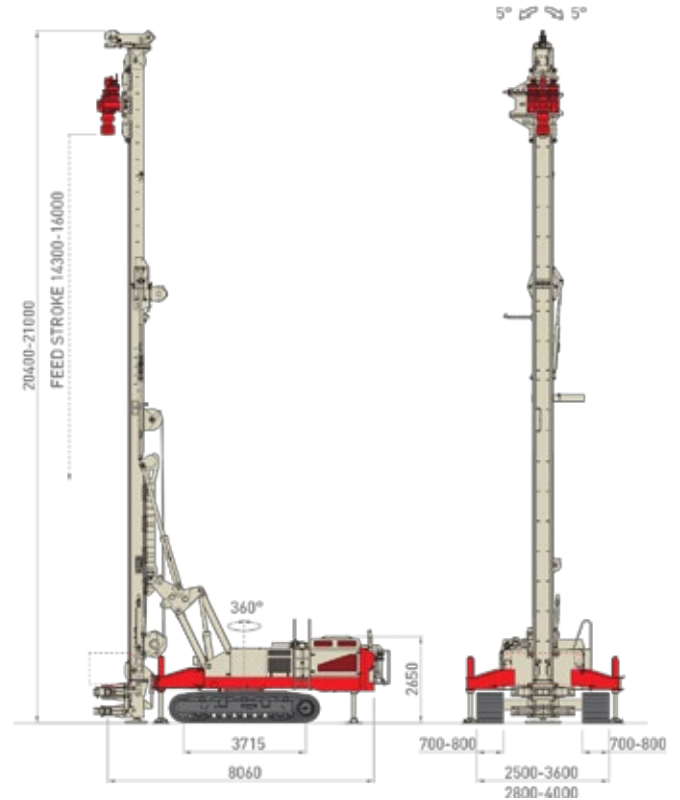
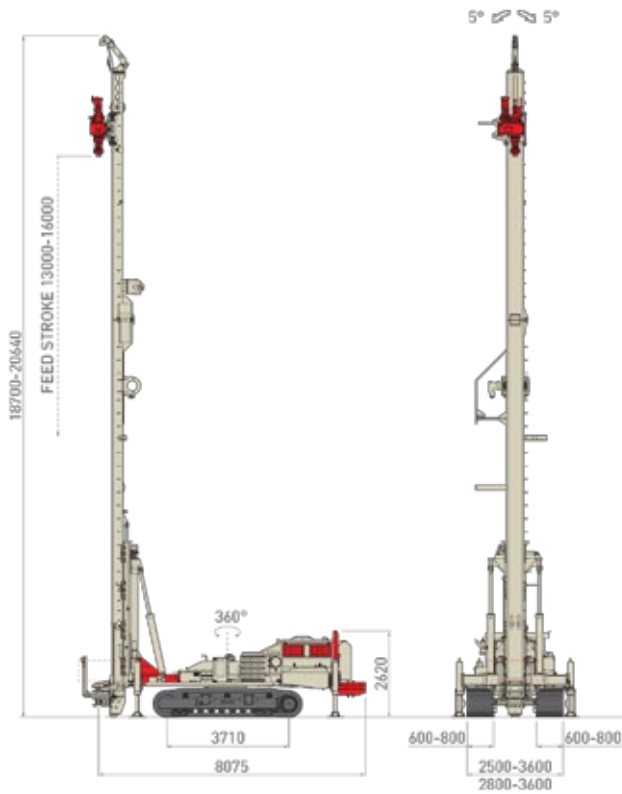

	MC 30		m.s.		i.s.		MC 40	
Potenza Motore Engine Power	188 - 205	252 - 275	kW	HP	188 - 205	252 - 275		
Livello Emissioni Emission Level	Step 3A / Tier 3 - Step 4 / Tier 4f (HT Line)				-			
Corsa Mast Mast Feed Stroke	13.000 - 16.000	42.6 - 52.4	mm	ft	14.300 - 16.000	46.9 - 52.4		
Forza di Spinta Feed Force	10.000 - 15.000	22,480 - 33,721	daN	lbs	30.000 - 37.000	67,442 - 83,179		
Forza di Tiro Retract Force	10.000 - 15.000	22,480 - 33,721	daN	lbs	30.000 - 37.000	67,442 - 83,179		
Coppia Rotary Rotary Torque Range	1.700 - 5.500	12,538 - 40,565	daNm	lb*ft	2.700 - 10.000	19,914 - 73,756		
Giri Rotary Rotary Speed Range	50 - 260		rpm		35 - 150			
Serraggio Morse Clamp Range	45 - 520	1.8 - 20.5	mm	in	60 - 600	2.4 - 23.6		
Peso Weight	33.000 - 38.000	72,700 - 83,700	kg	lbs	43.000 - 46.000	94,800 - 101,400		





## JET GROUTING

Il **Jet grouting** è una tecnica di consolidamento del terreno ampiamente diffusa, che utilizza getti di fluido ad altissima pressione per erodere il terreno, legandone i resti con una miscela cementizia fino a creare una massa omogenea di terreno consolidato.

A seconda dell'applicazione e dei tipi di terreno, vengono normalmente utilizzati tre tipi di **Jet grouting**:

- Jet grouting monofluido: la miscela è usata come unico fluido per erodere e consolidare il terreno.
- Jet grouting bifluido: un getto di aria compressa viene utilizzato unitamente alla miscela cementizia per aumentare l'efficacia dell'azione disgregante e ottenere diametri maggiori.
- Jet grouting trifluido: la disgregazione è data da uno o più getti d'acqua avvolti in cono di aria compressa, mentre la miscela cementizia viene iniettata attraverso uno o più ugelli posti sotto agli ugelli aria/acqua, ottenendo così diametri importanti di trattamento anche in terreni coesivi.

**Comacchio** offre una vasta gamma di perforatrici per jet grouting in grado di soddisfare svariate esigenze: dalle applicazioni all'interno di edifici ai trattamenti che superano i 30 m di profondità in singolo passaggio, resi possibili grazie all'utilizzo di idonee prolunghe mast di tipo telescopico.

*Jet grouting is a widely used and extremely versatile ground improvement technique that employs very high-pressure jets of fluid to erode the native soil and replace it with a soil-grout (cement) mixture to create a homogeneous mass of consolidated soil. Depending on the application and types of soils, three types of Jet grouting are normally used:*

- *Single Fluid Jet Grouting: only grout is used to simultaneously erode and cement the soil.*
- *Double Fluid Jet Grouting: grout is used with a coaxial jet of compressed air to increase the effectiveness of the erosive action and to obtain larger diameters.*
- *Triple Fluid Jet Grouting: the erosive action is given by one or more jets of water and compressed air, where the cementation is delivered by grout injected through one or more nozzles placed below the air/water nozzle(s), thus obtaining larger columns even in cohesive soils.*

**Comacchio** offers a wide range of jet grouting drill rigs that can be configured for low-headroom operation or for single pass treatment depths in excess of 30 m with the use of telescopic mast extensions.

### FULLY ARTICULATED Rigs



m.s.		i.s.		MC 8		MC 12		MC 14		MC 15	
Prof. Max Pass. Sing. Max Depth Single Pass	m	ft	12	39.3	12	39.3	12	39.3	19	62.3	
Diametro Asta Rod Size	mm	in	60 - 90	2.4 - 3.5	60 - 90	2.4 - 3.5	60 - 90	2.4 - 3.5	90 - 114	3.5 - 4.5	
Caricatore Aste Rod Carousel	m	ft	-		-		-		-		
Coppia Rotary Torque Range	daNm	lb*ft	450 - 1.550	3,319 - 11,432	1.300 - 2.325	9,588 - 17,148	1.300 - 2.325	9,588 - 17,148	1.300 - 3.100	9,588 - 22,864	
Potenza Motore Engine Power	kW	HP	86 - 100	115 - 134	95 - 115	127 - 154	129	173	119	160	
Peso Weight	kg	lbs	9.500	20,900	13.000	28,600	15.000	33,000	16.000	35,200	

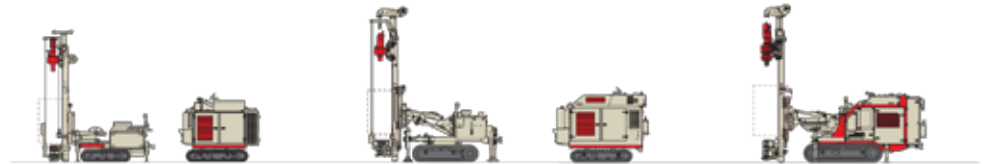

**LOW HEADROOM Rigs**

	m.s.	i.s.	MC 3D		MC 4D		MC 6	
Altezza Max. Max Height	mm	ft	2.000 - 3.300	6.5 - 10.8	2.200 - 3.400	6.5 - 11.1	2.200 - 3.400	6.5 - 11.1
Diametro Asta Rod Size	mm	in	60 - 90	2.4 - 3.5	60 - 114	2.4 - 4.5	60 - 114	2.4 - 4.5
Coppia Rotary Torque Range	daNm	lb*ft	300 - 510	2,212 - 3,761	450 - 1.100	3,319 - 8,113	450 - 1.400	3,319 - 10,325
Potenza Motore Engine Power	kW	HP	55	74	86 - 100	115 - 134	100	134
Peso Perforatrice Rig Weight	kg	lbs	3.000	6,600	5.000	11,000	6.500	14,300
Peso Centrale Power Pack Weight	kg	lbs	2.000 - 2.300	4,400 - 5,000	2.000 - 2.800	4,400 - 6,100	-	-



	m.s.	i.s.	MC 15P		MC 22		MC 28		MC 28 HD	
Prof. Max Pass. Sing. Max Depth Single Pass	m	ft	19	62.3	23	75.4	23	75.4	25	82.0
Diametro Asta Rod Size	mm	in	90 - 114	3.5 - 4.5	90 - 127	3.5 - 5.0	90 - 127	3.5 - 5.0	90 - 127	3.5 - 5.0
Caricatore Aste Rod Carousel	m	ft	-	-	2 x 4,5	2 x 14.7	2 x 4,5	2 x 14.7	2 x 4,5	2 x 14.7
Coppia Rotary Torque Range	daNm	lb*ft	1.700 - 3.100	12,538 - 22,864	1.700 - 3.100	12,538 - 22,864	2.400 - 5.500	17,701 - 40,565	2.400 - 5.500	17,701 - 40,565
Potenza Motore Engine Power	kW	HP	168	225	147 - 168	197 - 225	188 - 205	252 - 275	205	275
Peso Weight	kg	lbs	17.000	37,400	24.000	52,900	28.000	61,700	30.000	66,100



# JET GROUTING

## VERTICAL Rigs



	m.s.	i.s.	MC 10		MC 13		MC 21	
Prof. Max Pass. Sing. Max Depth Single Pass	m	ft	12	39.3	21	68.8	20	65.6
Diametro Asta Rod Size	mm	in	60 - 90	2.4 - 3.5	90 - 114	3.5 - 4.5	90 - 114	3.5 - 4.5
Caricatore Aste Rod Carousel	m	ft	-		-		-	
Coppia Rotary Torque Range	daNm	lb*ft	1.000 - 3.100	7,375 - 22,864	2.000 - 2.800	14,751 - 20,651	1.300 - 3.100	9,588 - 22,864
Potenza Motore Engine Power	kW	HP	115	154	160	214	168	225
Peso Weight	kg	lbs	11.000	24,200	16.500	36,300	22.000	48,500



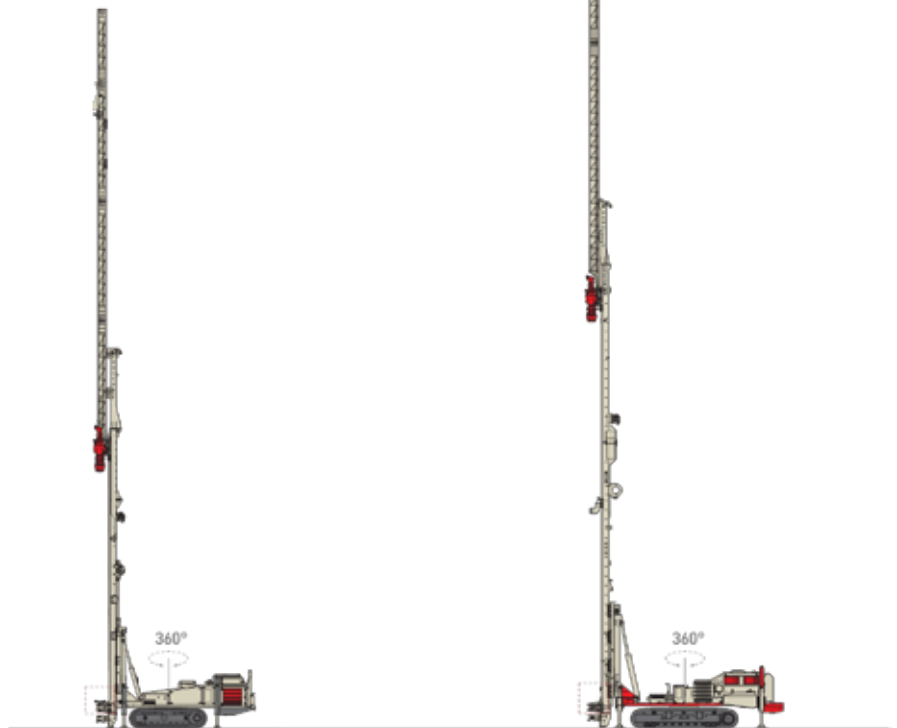

	m.s.	i.s.	<b>MC 24</b>		<b>MC 30</b>	
Prof. Max Pass. Sing. Max Depth Single Pass	m	ft	23	75.4	33	108.2
Diametro Asta Rod Size	mm	in	90 - 127	3.5 - 5.0	90 - 127	3.5 - 5.0
Caricatore Aste Rod Carousel	m	ft	-		2 x 9	2 x 29.5
Coppia Rotary Torque Range	daNm	lb*ft	2.400 - 2.800	17,701 - 20,651	1.700 - 2.800	12,538 - 20,651
Potenza Motore Engine Power	kW	HP	205	275	180 - 205	241 - 275
Peso Weight	kg	lbs	24.000	52,900	36.000	79,400





## LAVORAZIONI CON ELICA E METODO CFA

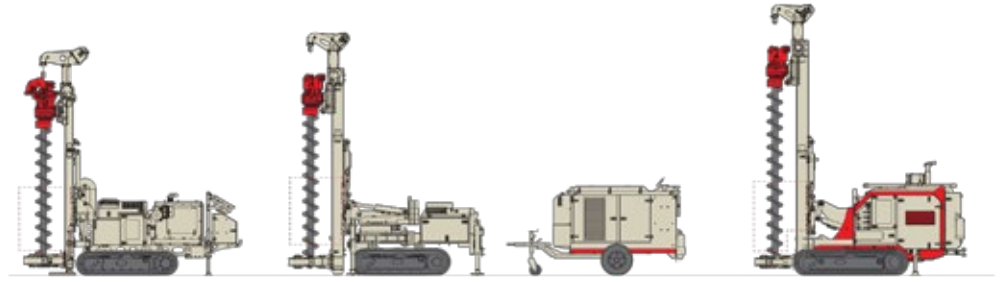

	m.s.	i.s.	<b>MC 4 F</b>		<b>MC 5D F</b>		<b>MC 6V F</b>	
Diametro Elica <i>Auger Diameter</i>	mm	in	200 - 450	7.8 - 17.7	200 - 450	7.8 - 17.7	300 - 450	11.8 - 17.7
Corsa Utile <i>Feed stroke</i>	mm	ft	1.400 - 2.400	4.5 - 7.8	1.450 - 2.750	4.7 - 9.0	1.450 - 3.300	4.7 - 10.8
Forza di Estrazione <i>Extraction Force</i>	daN	lbs	5.000	11,240	5.500	12,364	5.500	12,364
Coppia Max <i>Max torque</i>	daNm	lb*ft	2.325	17,148	2.325	17,148	2.325	17,148
Potenza Motore <i>Engine Power</i>	kW	HP	55	74	86 - 100	115 - 134	100	134
Peso Performatrice <i>Rig Weight</i>	kg	lbs	4.400	9,700	5.200	11,500	6.000	13,200
Peso Centrale <i>Power Pack Weight</i>	kg	lbs	-	-	2.100 - 2.800	4,600 - 6,100	-	-

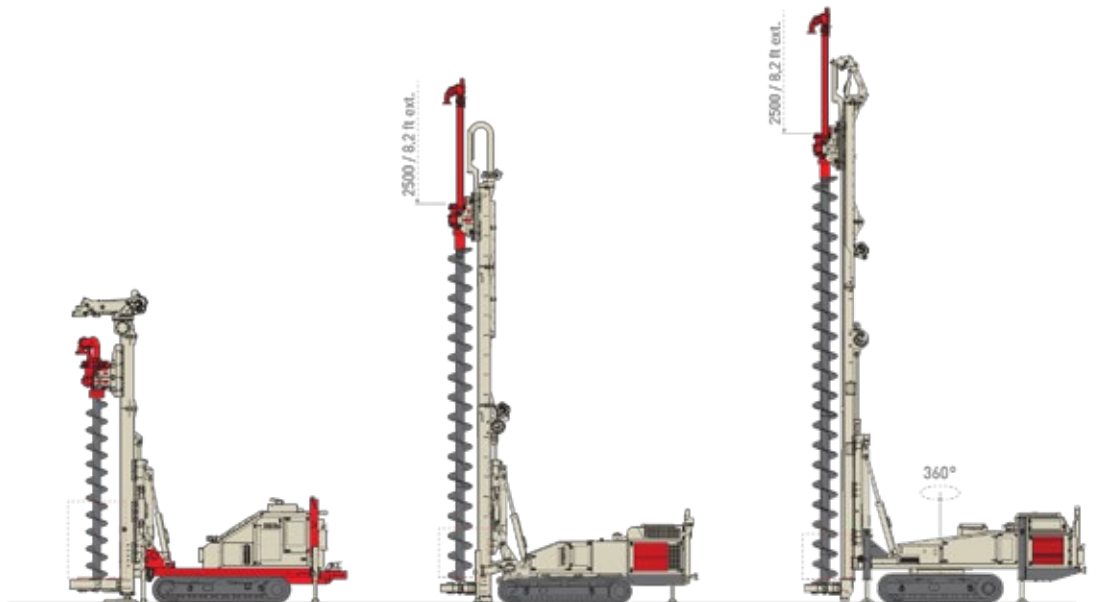

	m.s.	i.s.	<b>MC 10 F</b>		<b>MC 13 F</b>		<b>MC 24 F</b>	
Diametro Elica <i>Auger Diameter</i>	mm	in	350 - 600	13.7 - 23.6	350 - 750	13.7 - 29.5	350 - 750	13.7 - 29.5
Corsa Utile <i>Feed stroke</i>	mm	ft	2.100 - 3.500	6.8 - 11.4	3.100 - 8.600	10.1 - 28.2	7.200 - 10.200	23.6 - 33.5
Forza di Estrazione <i>Extraction Force</i>	daN	lbs	8.000	17,984	19.500	43,837	19.500	43,837
Coppia Max <i>Max torque</i>	daNm	lb*ft	3.100	22,864	5.500	40,565	5.500	40,565
Potenza Motore <i>Engine Power</i>	kW	HP	115	154	160	215	205	275
Peso <i>Weight</i>	kg	lbs	10.000	22,000	16.000	35,200	24000	52,900





La tecnologia dei **pali ad elica continua (CFA)** è uno dei metodi più diffusi di esecuzione di pali trivellati e gettati in opera. Il processo si basa sull'utilizzo di eliche cave che inizialmente vengono infisse nel terreno con una velocità di penetrazione costante. L'elica viene poi lentamente estratta e il calcestruzzo viene simultaneamente pompato attraverso la cavità dell'elica al fine di creare il palo. La gamma **Comacchio** offre una vasta scelta di perforatrici **VERTICALI MULTIFUNZIONE** che possono essere fornite in "configurazione F", studiata per la realizzazione di pali con l'utilizzo del metodo **CFA** o di eliche tradizionali, con o senza rivestimento.

*Continuous flight auger (CFA) is one of the most common cast in-situ methods of piling. The process uses hollow stem augers. First, the auger is drilled to the final depth at a constant penetration rate, the auger is slowly extracted; at the same time, the concrete is pumped to the ground through the auger hollow stem forming the concrete pile. Comacchio offers a wide range of VERTICAL MULTIPURPOSE drill rigs that can be supplied in "F-configuration" for mini piling using hollow stem CFA augers and solid stem augers, with both cased and uncased systems.*

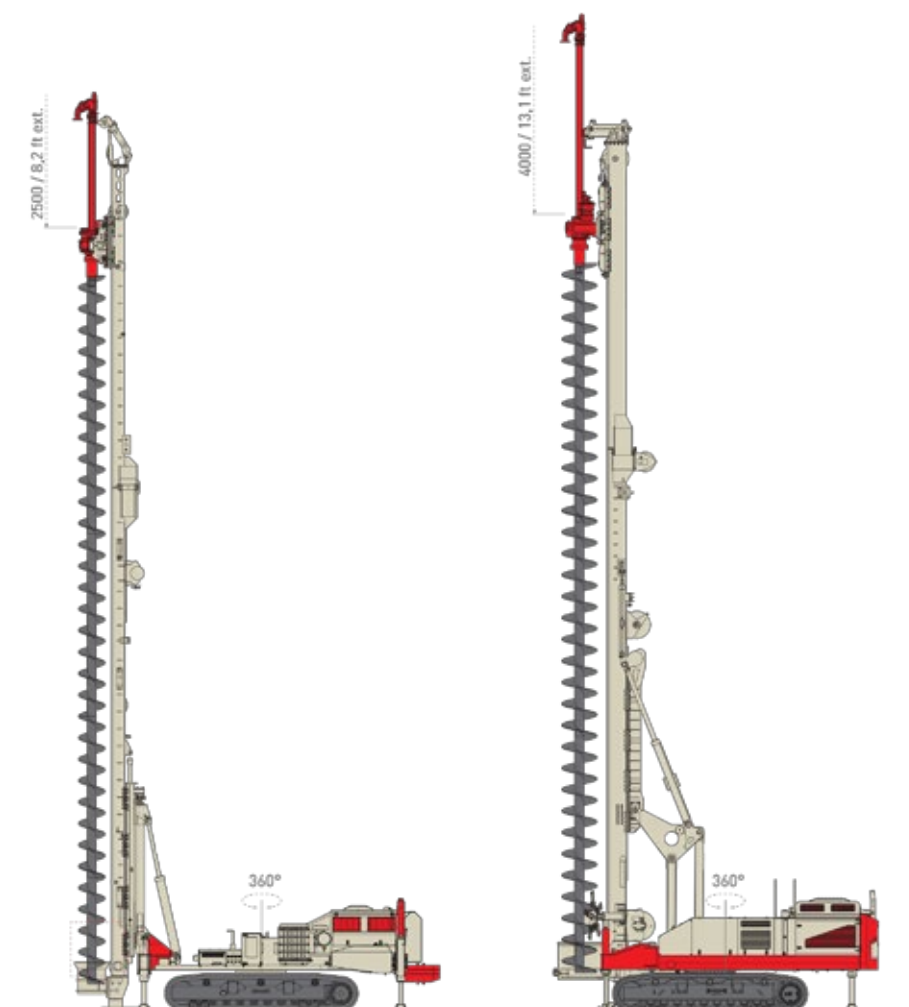

	m.s.	i.s.	MC 30 <b>F</b>		MC 40 <b>F</b>	
Diametro Elica Auger Diameter	mm	in	350 - 750	13.7 - 29.5	400 - 800	15.7 - 31.4
Corsa Utile Feed stroke	mm	ft	13.000 - 16.000	42.6 - 52.4	16.000	52.4
Forza di Estrazione Extraction Force	daN	lbs	15.000	33,721	30.000	67,442
Coppia Max Max torque	daNm	lb*ft	5.500	40,565	10.000	73,756
Potenza Motore Engine Power	kW	HP	188 - 205	252 - 275	188 - 205	252 - 275
Peso Weight	kg	lbs	35.000	77,100	45.000	99,200

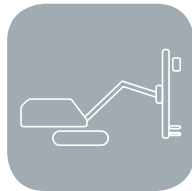

## Perforatrici Multifunzione **A SBRACCIO LUNGO** **LONG REACH** Multipurpose Rigs



Perforatrici con articolazione del mast di tipo "long reach" (a sbraccio lungo) che garantisce ampi raggi di lavoro in condizioni di spazi ristretti e di difficile accesso, ideali per l'esecuzione di opere di consolidamento o di sostegno di pareti e fronti di scavo con tecniche di perforazione a rotazione o rotoperussione e in particolare con l'uso di sistemi a barre autoperforanti.

*Compact drill rigs featuring a double boom "long reach" mast design to handle restricted or difficult site locations, ideally suited for anchored retaining walls and slope stabilization, soil nailing using both rotary and rotary-percussive drilling techniques, in particular, self-drilling hollow bar systems.*

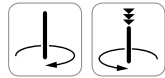
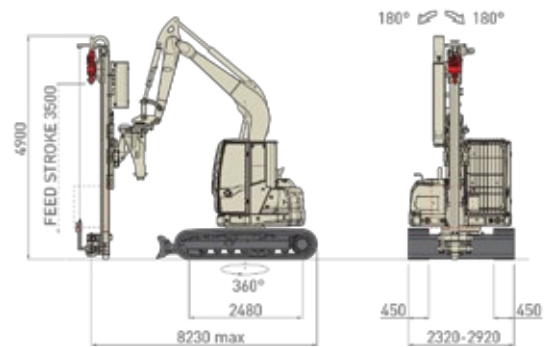
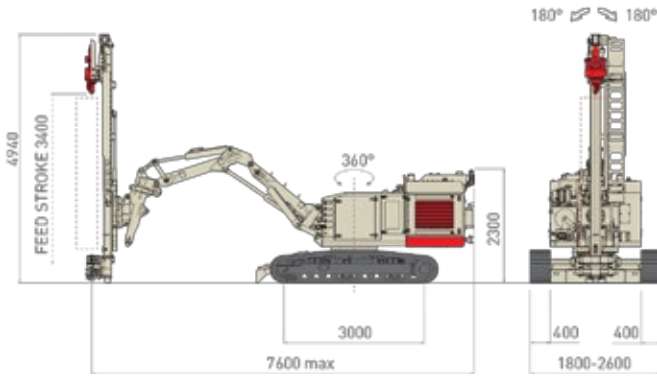

m.s. i.s.

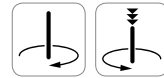

Potenza Motore Engine Power	100	134	kW	HP	53.7 - 63	72 - 85	
Livello Emissioni Emission Level	<b>Step 4 / Tier 4f (HT Line)</b>		-				<b>Step 3A / Tier 3 - Step 3B / Tier 4f (HT Line)</b>
Corsa Mast Mast Feed Stroke	3.400	11.1	mm	ft	3.540	11.6	
Forza di Spinta Feed Force	2.500	5,620	daN	lbs	2.500	5,620	
Forza di Tiro Retract Force	2.500	5,620	daN	lbs	2.500	5,620	
Coppia Rotary Rotary Torque Range	160 - 440	1,180 - 3,245	daNm	lb*ft	200 - 430	1,475 - 3,171	
Giri Rotary Rotary Speed Range	72 - 400		rpm		75 - 560		
Serraggio Morse Clamp Range	32 - 170	1.2 - 6.7	mm	in	45 - 170	1.8 - 6.7	
Peso Weight	9.500 - 10.000	20,000 - 22,00	kg	lbs	13.000	28,600	



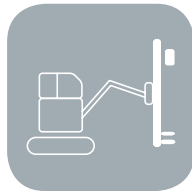

## Mast per Escavatori **MC-E** **MC-E** Drilling Attachments



Mast di perforazione applicati su escavatori, progettati per affrontare situazioni di lavoro particolari, dove le condizioni e gli spazi di lavoro impediscono l'uso di una macchina perforatrice cingolata convenzionale.

*Excavator boom mounted drilling masts for special operations in limited and open job-sites, reaching over obstacles and operating on slopes. This low bearing pressure equipment is the the answer where traditional crawler drills can't be used.*

# MC-E 12

# MC-E 25

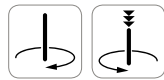
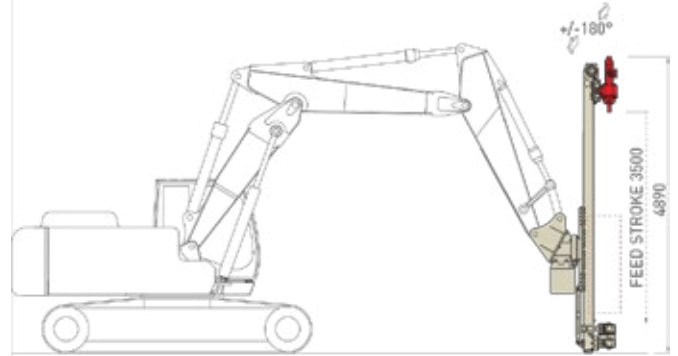
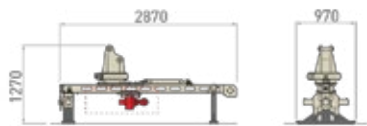
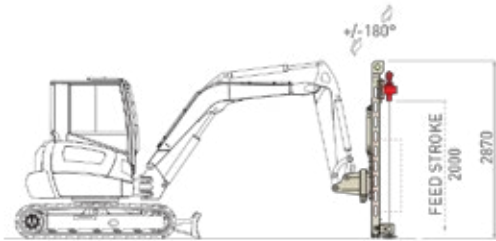

m.s. i.s.

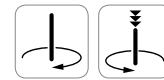

Classe Escavatore Excavator Class	5		ton		15	
Corsa Mast Mast Feed Stroke	2.050	6.7	mm	ft	3.540	11.6
Forza di Spinta Feed Force	1.200	2,697	daN	lbs	2.500	5,620
Forza di Tiro Retract Force	1.200	2,697	daN	lbs	2.500	5,620
Coppia Rotary Rotary Torque Range	230 - 360	1,696 - 2,655	daNm	lb*ft	80 - 440	590 - 3,245
Giri Rotary Rotary Speed Range	100 - 160		rpm		72 - 560	
Serraggio Morse Clamp Range	45 - 185	1.8 - 7.3	mm	in	45 - 170	1.8 - 6.7
Peso Weight	500 - 600	1,100 - 1,300	kg	lbs	1.500 - 1.600 kg	3,300 - 3,500





# MC-E 30

# MC-E 40

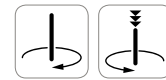
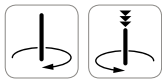
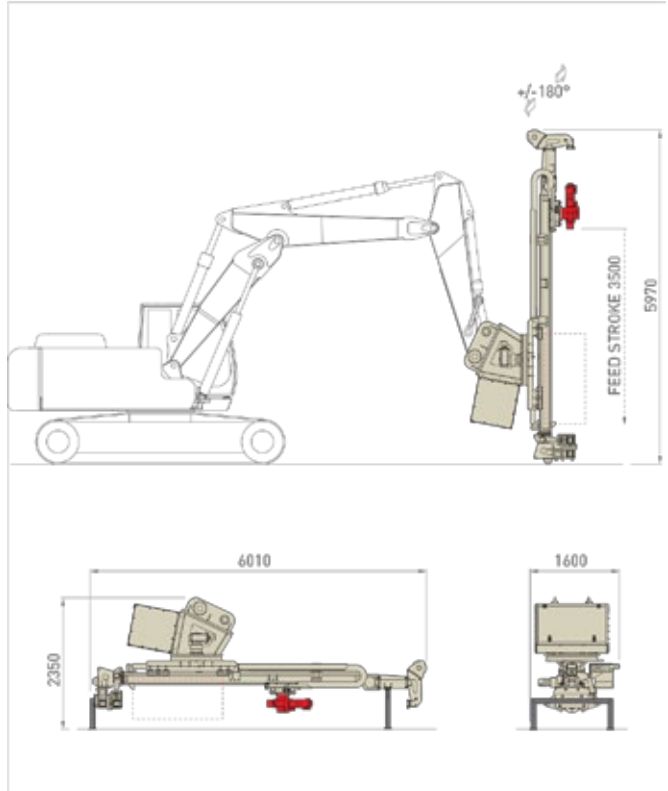
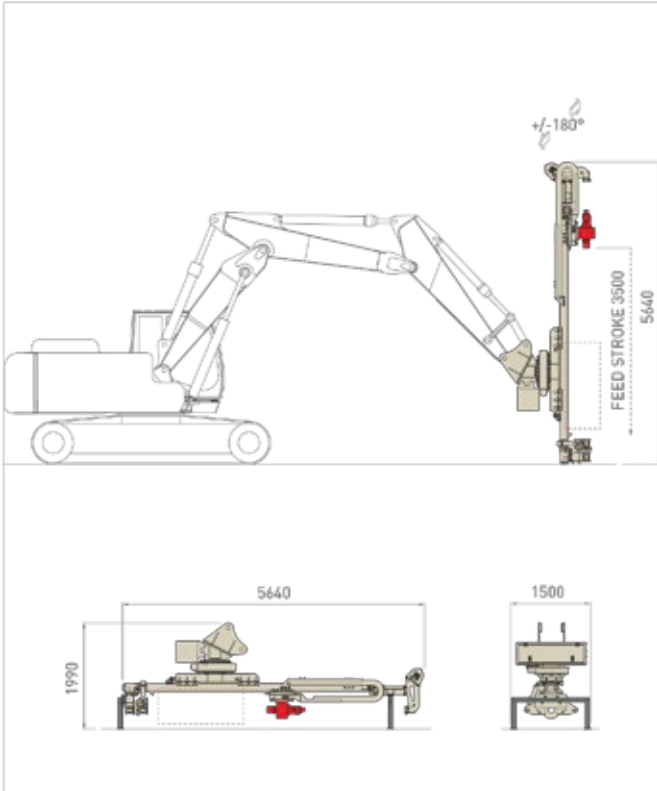

			m.s.	i.s.		
Classe Escavatore Excavator Class	14 - 15		ton		18 - 20	
Corsa Mast Mast Feed Stroke	3.500	11.4	mm	ft	1.650 - 3.500	5.4 - 11.4
Forza di Spinta Feed Force	3.500	7,868	daN	lbs	5.000	11,240
Forza di Tiro Retract Force	3.500	7,868	daN	lbs	5.000	11,240
Coppia Rotary Rotary Torque Range	80 - 1.400	590 - 10,325	daNm	lb*ft	80 - 1.400	590 - 10,325
Giri Rotary Rotary Speed Range	72 - 400		rpm		43 - 400	
Serraggio Morse Clamp Range	45 - 220	1.8 - 8.7	mm	in	45 - 260	1.8 - 10.4
Peso Weight	2.300 - 2.500	5,000 - 5,500	kg	lbs	2.500 - 3.500	5,500 - 7,700



# MC-E 45

# MC-E 60

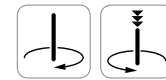
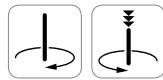
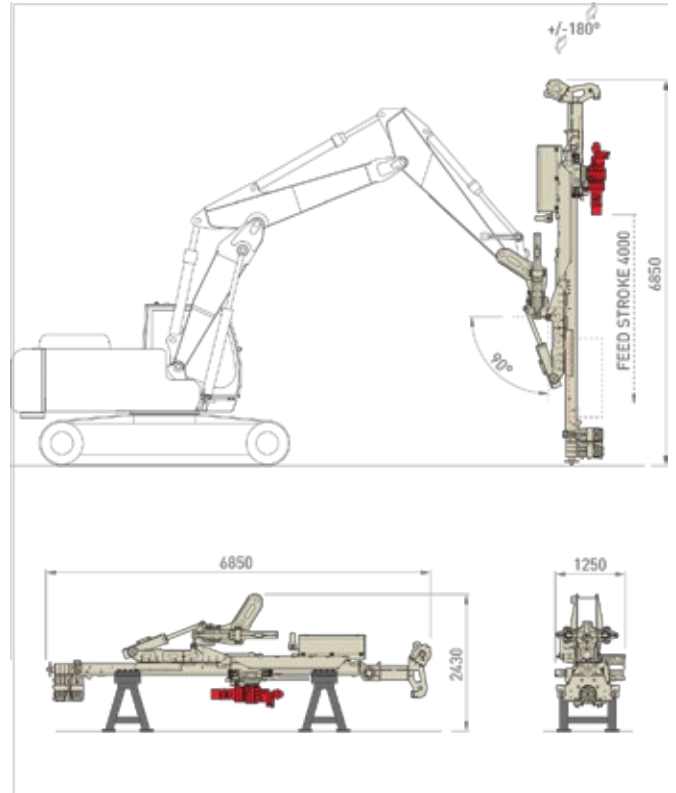
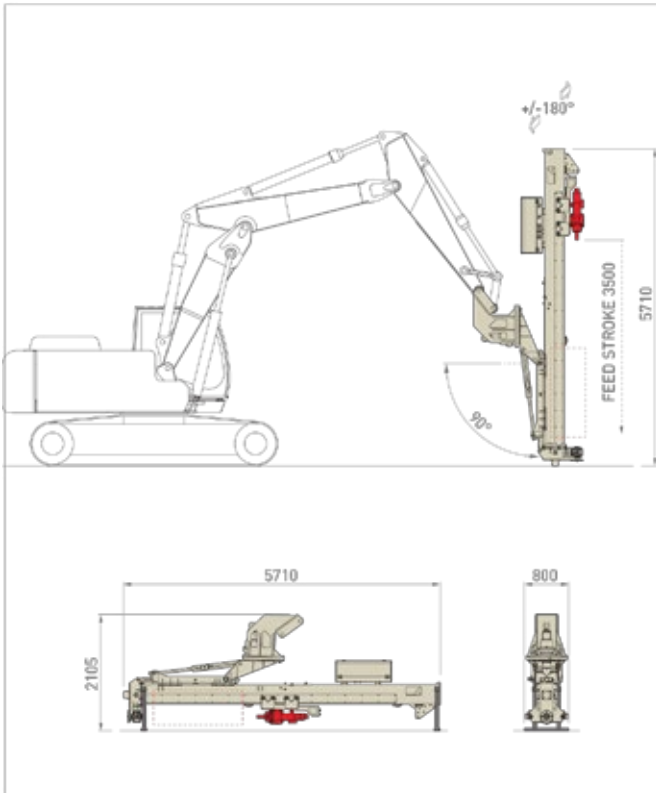

	18 - 20		25 - 30	
Classe Escavatore Excavator Class	18 - 20		25 - 30	
Corsa Mast Mast Feed Stroke	3.500	11.4	4.000	13.1
Forza di Spinta Feed Force	2.750	6,180	5.500	11,364
Forza di Tiro Retract Force	4.500	10,110	5.500	11,364
Coppia Rotary Rotary Torque Range	80 - 440	590 - 3,245	80- 1.550	590 - 11,430
Giri Rotary Rotary Speed Range	72 - 560		43 - 400	
Serraggio Morse Clamp Range	45 - 170	1.8 - 6.8	45 - 360	1.8 - 14.1
Peso Weight	2.500 - 3.000	5,500 - 6,600	4.000 - 4.500	8,800 - 9,900





# MC-E 80

# MC-E 100

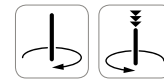
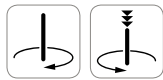
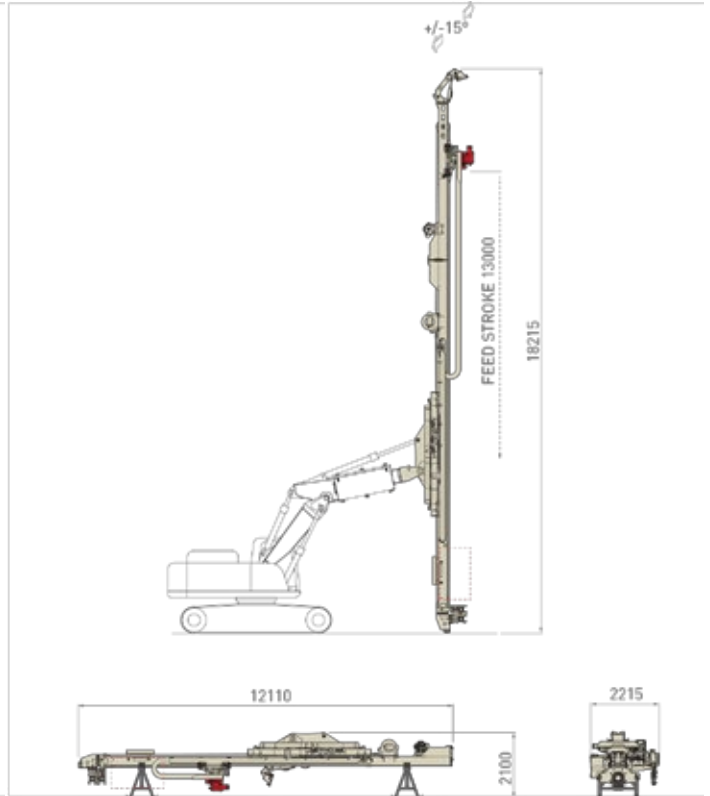
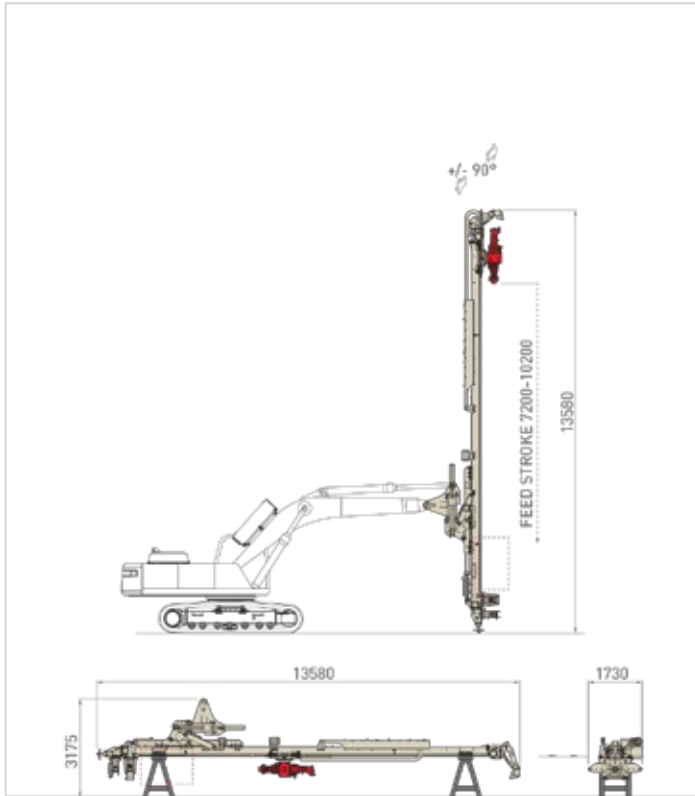

m.s. i.s.

Classe Escavatore Excavator Class	35 - 36		ton		40 - 50	
Corsa Mast Mast Feed Stroke	3.450 - 10.200	11.3 - 33.4	mm	ft	13.000	42.6
Forza di Spinta Feed Force	8.000	17,984	daN	lbs	10.000	22,480
Forza di Tiro Retract Force	8.000	17,984	daN	lbs	15.000	33,721
Coppia Rotary Rotary Torque Range	1.500 - 3.000	11,063 - 22,126	daNm	lb*ft	800 - 3.200	5,900 - 23,602
Giri Rotary Rotary Speed Range	48 - 260		rpm		22 - 150	
Serraggio Morse Clamp Range	45 - 420	1.8 - 16.5	mm	in	45 - 420	1.8 - 16.5
Peso Weight	9.000 - 10.000	19,800 + 22,000	kg	lbs	10.000 - 10.500	22,000 - 23,000







## Posizionatore per **GALLERIA** **TUNNELING** Rigs



Posizionatori utilizzati per opere di impermeabilizzazione e consolidamento del terreno legate alla realizzazione di gallerie, compresa l'installazione di micropali sub-orizzontali (ombrello), interventi di jet grouting o altre tecniche di iniezione. La MC 30 TX, in particolare, può essere convertita in una perforatrice standard.

*Drilling rigs used for waterproofing and ground improvement works in tunnel construction projects, including forepiling applications (umbrella drilling), jet grouting and other injection grouting applications. The MC 30 TX can be also converted into a standard micro piling machine.*



# MC 30 TX

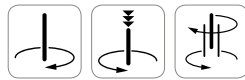
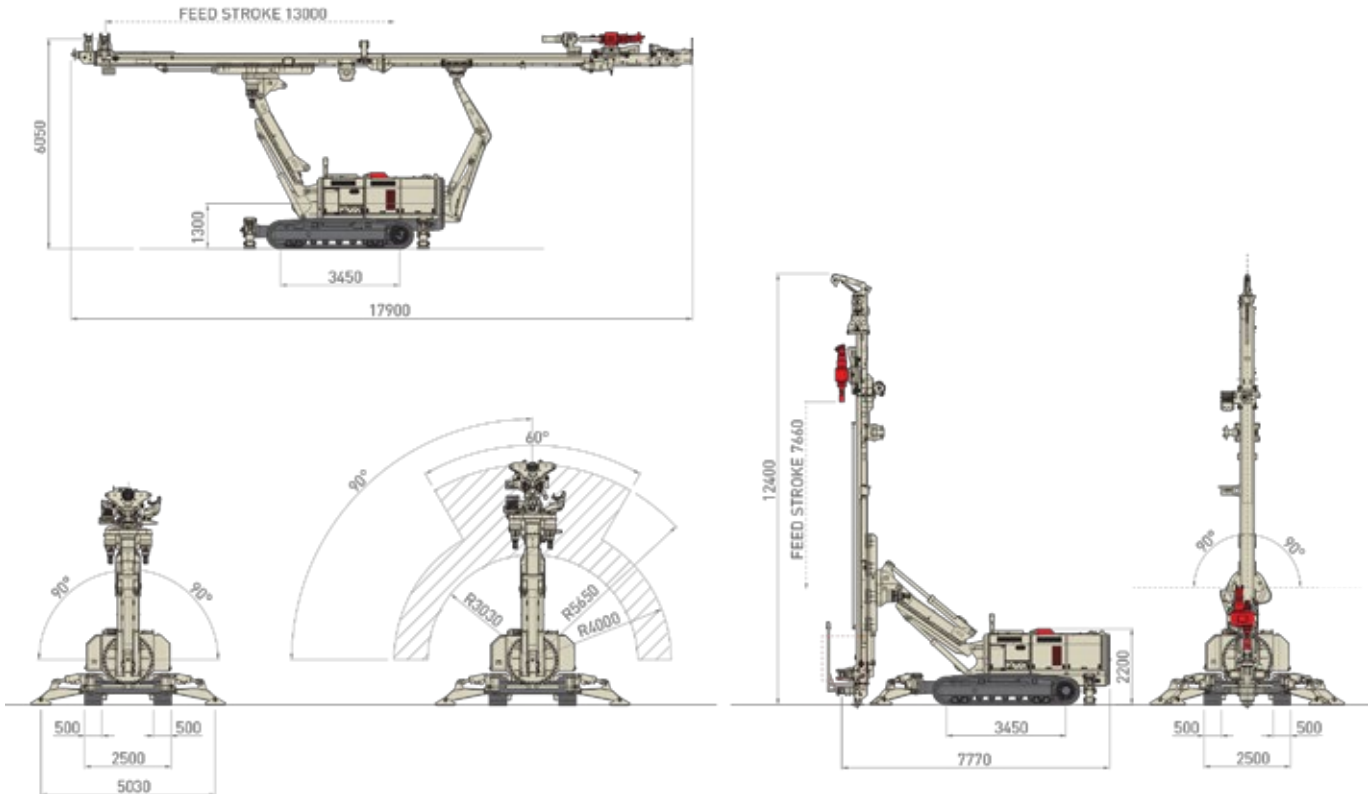

	m.s.	i.s.		
Potenza Motore Engine Power	kW	HP	147 - 160	197 - 214
Livello Emissioni Emission Level	Step 3A / Tier 3 - Step 4 / Tier 4f (HT Line)			
Corsa Mast Mast Feed Stroke	mm	ft	7.000 - 13.000	22.9 - 42.6
Forza di Spinta Feed Force	daN	lbs	8.000	17,984
Forza di Tiro Retract Force	daN	lbs	8.000	17,984
Coppia Rotary Rotary Torque Range	daNm	lb*ft	1.300- 2.000	9,588 - 14,751
Giri Rotary Rotary Speed Range	rpm		150 - 350	
Serraggio Morse Clamp Range	mm	in	45 - 360	1.8 - 14.2
Peso Weight	kg	lbs	30.000 - 33.000	66,000 - 72,700





## Perforatrici e Attrezzature **SPECIALI** *SPECIAL Rigs and Equipment*



Perforatrice speciale su camion per lavori di consolidamento e sondaggi su tracciati ferroviari  
*Special truck mounted drill rig for investigation works and ground improvement along railway lines.*



Perforatrice speciale MC-S 12 su piattaforma progettata per l'esecuzione di compensation grouting all'interno di pozzi  
*Special unit MC-S 12 designed to perform compensation grouting inside shafts.*



Perforatrice speciale su skid per perforazioni orizzontali  
*Special skid mounted drill rig for horizontal drilling*



Manipolatore per aste e rivestimenti CPH  
*CPH rod and casing handling unit*

Soluzioni tecniche e attrezzature speciali altamente personalizzate progettate e realizzate per soddisfare esigenze specifiche e affrontare lavorazioni particolari.

*Engineered solutions and highly customized special purpose equipment designed to specific requirements, tailored to meet the customer's need and carry out particular drilling tasks.*



**Comacchio s.r.l.**

Via Callalta, 24/B - 31039 Riese Pio X (TV) (Italy)

Tel +39 0423 7585 - Fax + 39 0423 755592 - [sales@comacchio.com](mailto:sales@comacchio.com)